







ALTEST

ALUMINIUM PROFILE SYSTEMS

MINI SLIDING

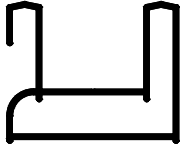
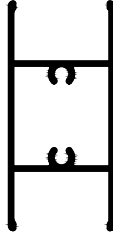
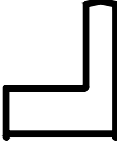
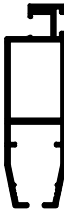
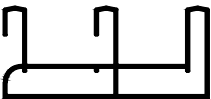
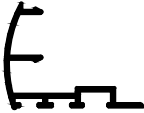
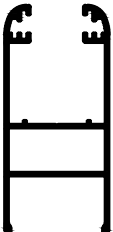

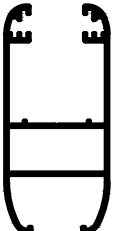



PROFILES OVERVIEW

Profile shape	Profile code / description	Weight (gr/m)	Profile shape	Profile code / description	Weight (gr/m)
	1001 Frame profile	651		1024 Mullion profile	650
	1004 Frame profile	420		1031 Mosquito profile	501
	1005 Frame profile	1060		1041 Addition for double wing profile	288
	1011 Sash profile	688		1051 Drop defender profile	270
	1012 Sash profile	704		1071 Adaptor profile	211

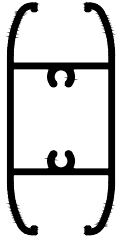
WARNING: ALL OF THE PROFILE WEIGHTS ARE THEORETICAL.

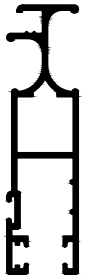
PROFILES OVERVIEW

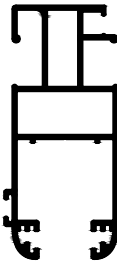
Profile shape	Profile code / description	Weight (gr/m)	Profile shape	Profile code / description	Weight (gr/m)
	2022 Sash profile	694			
	2042 Glass holder profile	230			
	300 0128 Mosquito profile	661			
	NEW * 1061 Frame adaptor	256			
	NEW * 1015 Mosquito profile	828			

WARNING: ALL OF THE PROFILE WEIGHTS ARE THEORETICAL.

MINI SLIDING SYSTEM

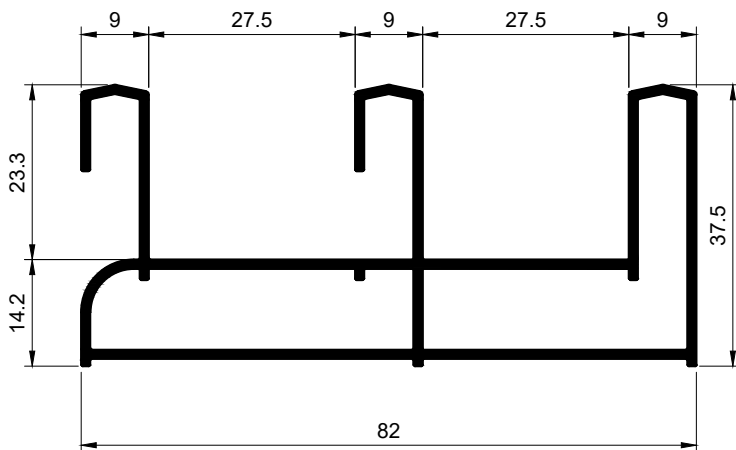
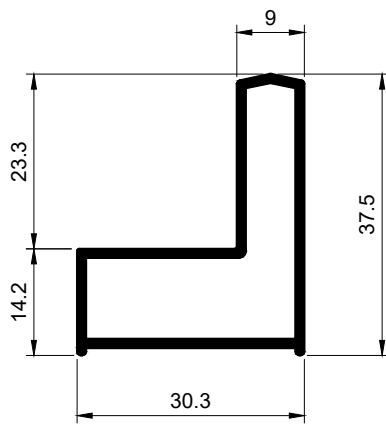
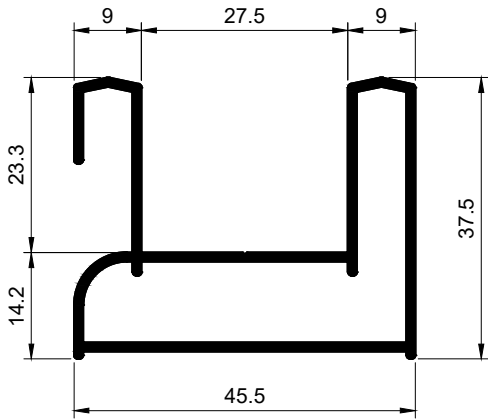

1001 Frame profile		Weight (gr/m)	I_x / I_y (cm ⁴)	W_x / W_y (cm ³)
		651	3,48/6,48	1,66/2,72
JOINTS	 APE 4		STOPPER	 AMS 11
BRUSHES	 AMS07			

1004 Frame profile		Weight (gr/m)	I_x / I_y (cm ⁴)	W_x / W_y (cm ³)
		420	2,06/1,63	0,91/0,86
JOINTS	 APE 4		STOPPER	 AMS 11
BRUSHES				

1005 Frame profile		Weight (gr/m)	I_x / I_y (cm ⁴)	W_x / W_y (cm ³)
		1060	5,56/28,81	2,55/6,81
JOINTS	 APE 4		STOPPER	 AMS 11
BRUSHES	 AMS07			

MINI SLIDING SYSTEM

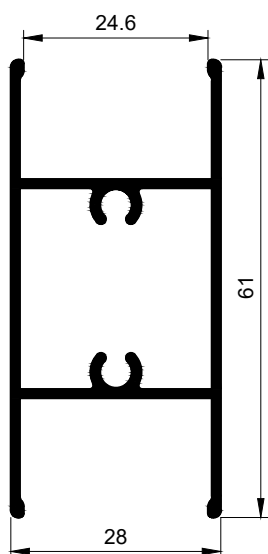
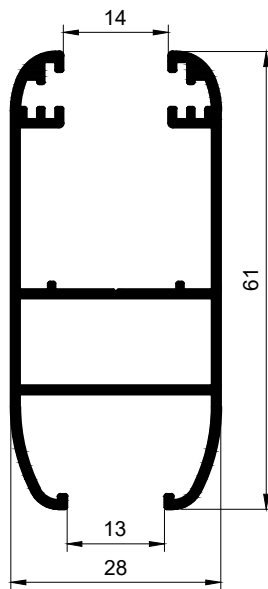
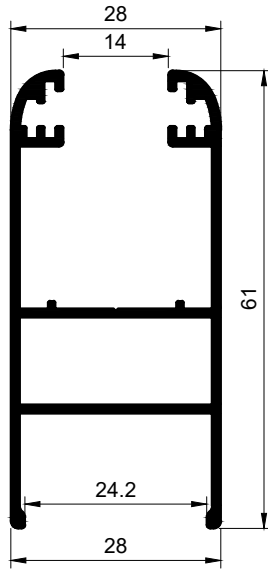





1011 Sash profile		Weight (gr/m)	I_x / I_y (cm ⁴)	W_x / W_y (cm ³)
		688	7,97/3,37	2,47/2,41
JOINTS	APE 5	APE 6	SHOCK DAMPER	A 0330
ROLLER FIT	A 0204	GASKETS	U 00.0; U 2;	BRUSHES TZ 5.5

1012 Sash profile		Weight (gr/m)	I_x / I_y (cm ⁴)	W_x / W_y (cm ³)
		704	8,53/3,28	2,70/2,34
JOINTS	APE 5	APE 6	SHOCK DAMPER	A 0330
ROLLER FIT	A 0204	GASKETS	U 00.0; U 2;	BRUSHES TZ 5.5

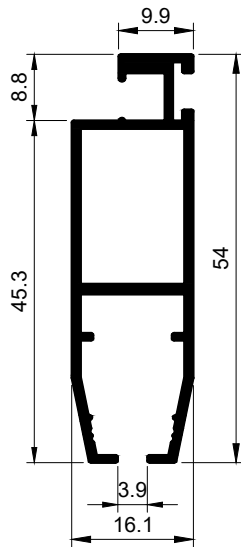
1024 Mullion profile		Weight (gr/m)	I_x / I_y (cm ⁴)	W_x / W_y (cm ³)
		650	6,39/3,03	2,10/2,16
JOINTS	VM 12212			
GASKETS	U 00.0; U 2;			

MINI SLIDING SYSTEM

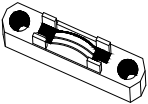
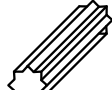

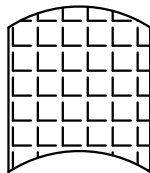
1031 Mosquito profile		Weight (gr/m)	I_x/ I_y (cm ⁴)	W_x/ W_y (cm ³)
		501	4,91/0,69	1,70/0,79
JOINTS			ROLLER FIT	
	AMS13	AMS14		AMS 20
GASKETS			BRUSHES	
	UK 6			TZ 18.0
MOSQUITO NET	FL 80; FL100; FL 120; FL 140; FL 160.			

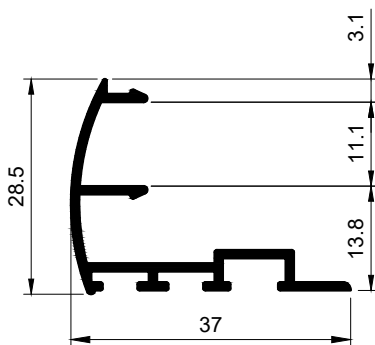

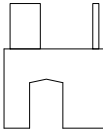
1041 Addition for double wing profile		Weight (gr/m)	I_x/ I_y (cm ⁴)	W_x/ W_y (cm ³)
		291	0,74/1,21	0,38/0,48
BRUSHES				
	TZ 5.5 TZ 18.0			
COVER				
	AMS 903			

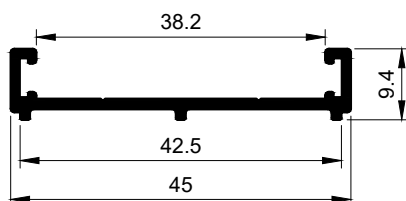

NEW *

1061 Frame adaptor	Weight (gr/m)
	256

MINI SLIDING SYSTEM

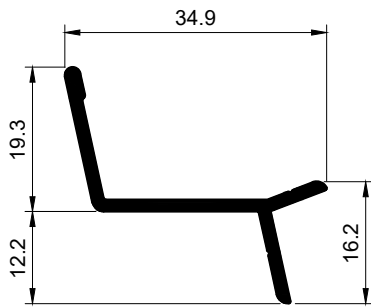

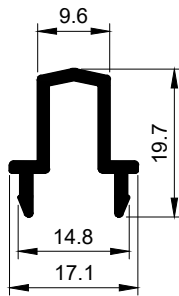

1051 Drop defender profile		Weight (gr/m)	I_x / I_y (cm ⁴)	W_x / W_y (cm ³)
		270	0,47/1,29	0,28/0,68
JOINTS				
GASKETS				

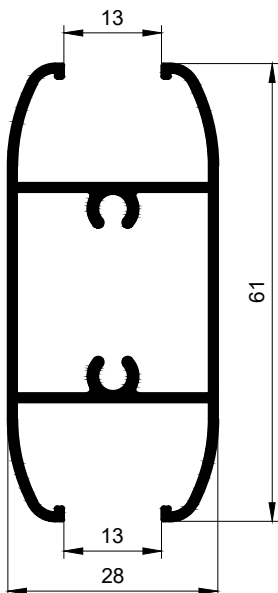

1071 Adaptor profile		Weight (gr/m)	I_x / I_y (cm ⁴)	W_x / W_y (cm ³)
		211	0,25/0,19	0,24/0,22
JOINTS	 VM46W			
GASKETS				

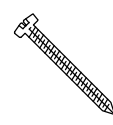
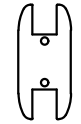

2022 Sash profile		Weight (gr/m)	I_x / I_y (cm ⁴)	W_x / W_y (cm ³)
		694	7,61/2,89	2,50/2,06
JOINTS	 VM 12212		COVER	 COVER CAP AMS 30
GASKETS	 U 00.0; U 2;			

MINI SLIDING SYSTEM

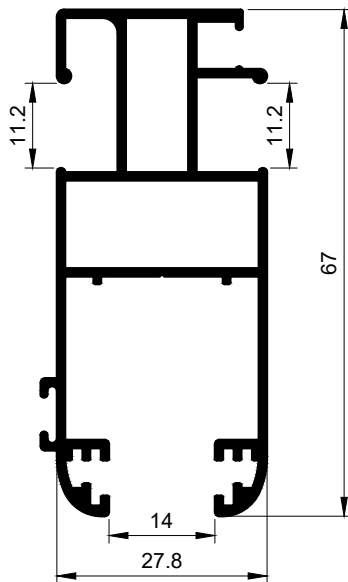
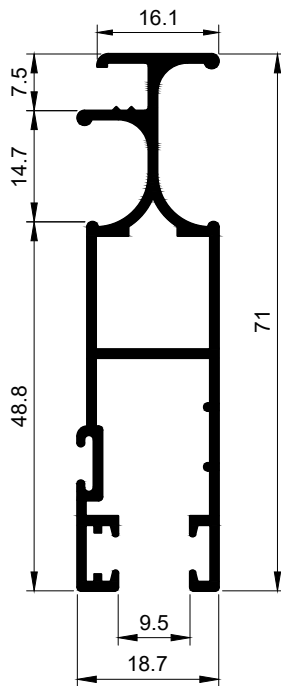
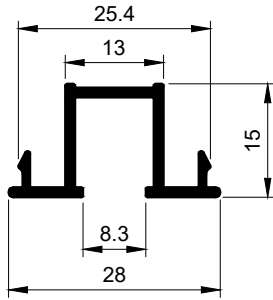

	2042 Glass holder profile	Weight (gr/m)	I_x / I_y (cm ⁴)	W_x / W_y (cm ³)
		230	0,23/0,50	0,26/0,36
GASKETS	 U 00.0; U 2;			

	300 0128 Mosquito profile	Weight (gr/m)	I_x / I_y (cm ⁴)	W_x / W_y (cm ³)
		661	11,79/1,07	3,29/1,14
JOINTS	 APE 157	ROLLER FIT	 A 0103	
BRUSHES	 TZ 5.5 TZ 18	GASKETS	 UK 7	
MOSQUITO NET	FL 80; FL 100; FL 120; FL 140; FL 160.			



NEW *

	1015 Mosquito profile	Weight (gr/m)	I_x / I_y (cm ⁴)	W_x / W_y (cm ³)
		828	11,79/1,07	3,29/1,14
JOINTS	 APE 5 APE 6	ROLLER FIT	 A 0204	
BRUSHES	 TZ 5.5 TZ 7 TZ 18	GASKETS	 UK 6	
MOSQUITO NET	FL 80; FL 100; FL 120; FL 140; FL 160.			

ACCESSOIRES

CODE	DROWING	DESCRIPTION	PACKING TYPE		
APE 4		ANGLE FIT	1 Package	250 Counts	
APE 5		ANGLE FIT	1 Package	250 Counts	
APE 6		ANGLE FIT	1 Package	1000 Counts	
A 0204		ROLLER FIT	1 Package	150 Counts	
AMS 20		ROLLER FIT	1 Package	300 Counts	
A 0103		ROLLER FIT	1 Package	300 Counts	
AMS 13		ANGEL FIT	1 Package	150 Counts	
AMS 14		ANGEL FIT	1 Package	150 Counts	
APE 157		ANGEL FIT	1 Package	150 Counts	
A 0330		SHOCK DAMPER	1 Package	640 Counts	

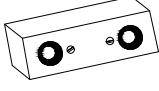
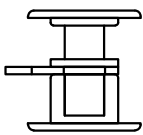
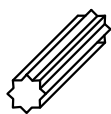
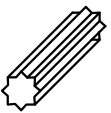
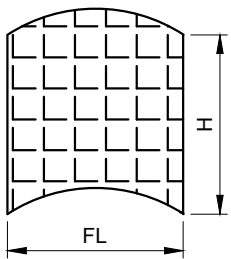
ACCESSOIRES

CODE	DROWING	DESCRIPTION	PACKING TYPE	
AMS 11		STOPPER		
D 7610		LOCKING CUP + HANDLE	1 Package	30 Counts
UK 6		EPDM gasket for 1031		
UK 7		EPDM gasket for 300 0128		
FL 80; FL100; FL 120; FL 140; FL 160.		MOSQUITO NET		
U 00.0; U 2;		EPDM gasket for glass fixing		

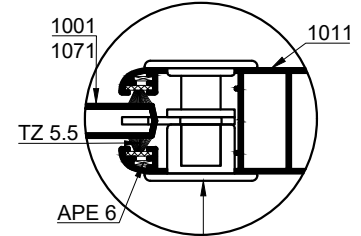

LOCKING CUP
+HANDLE

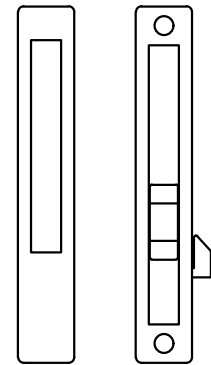

LOCKING CUP
+ HANDLE

1

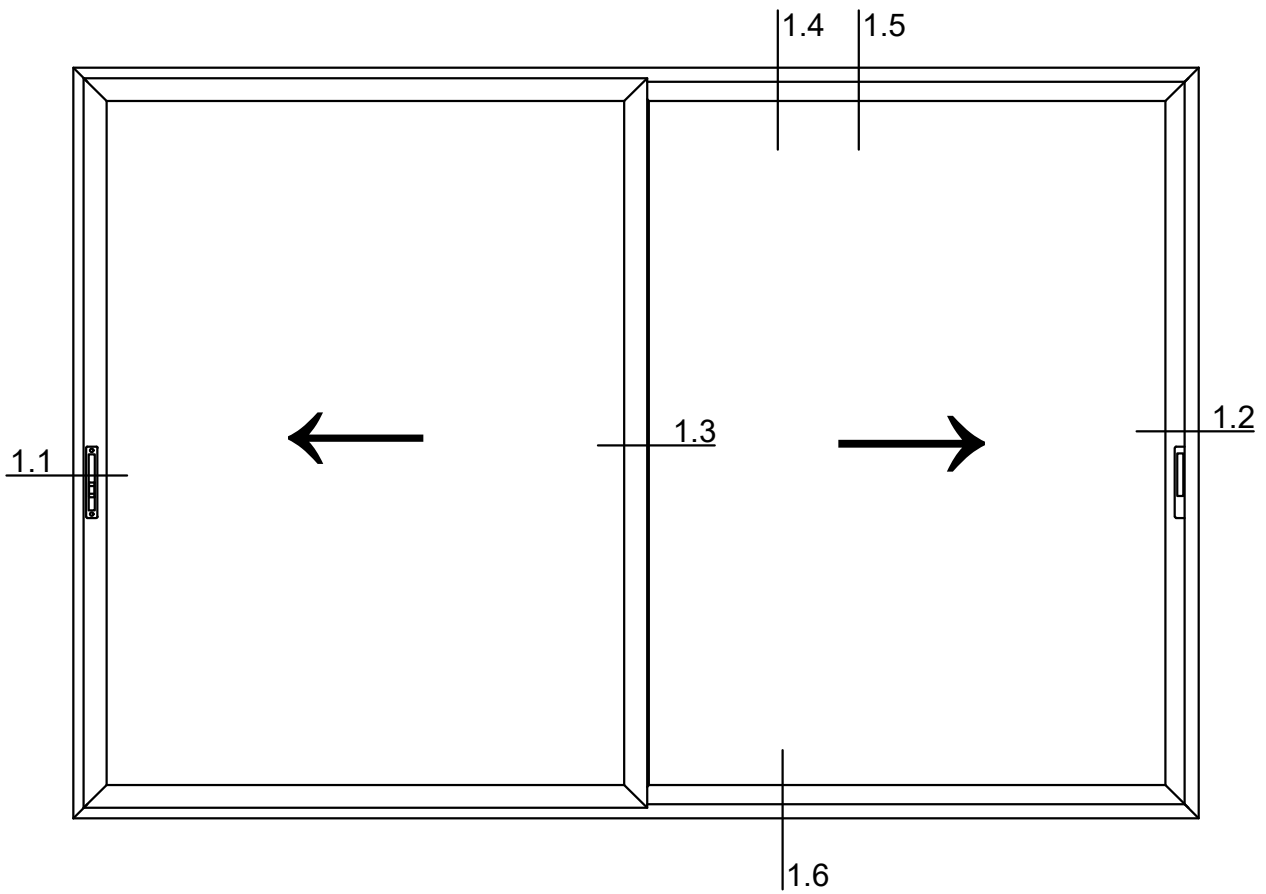

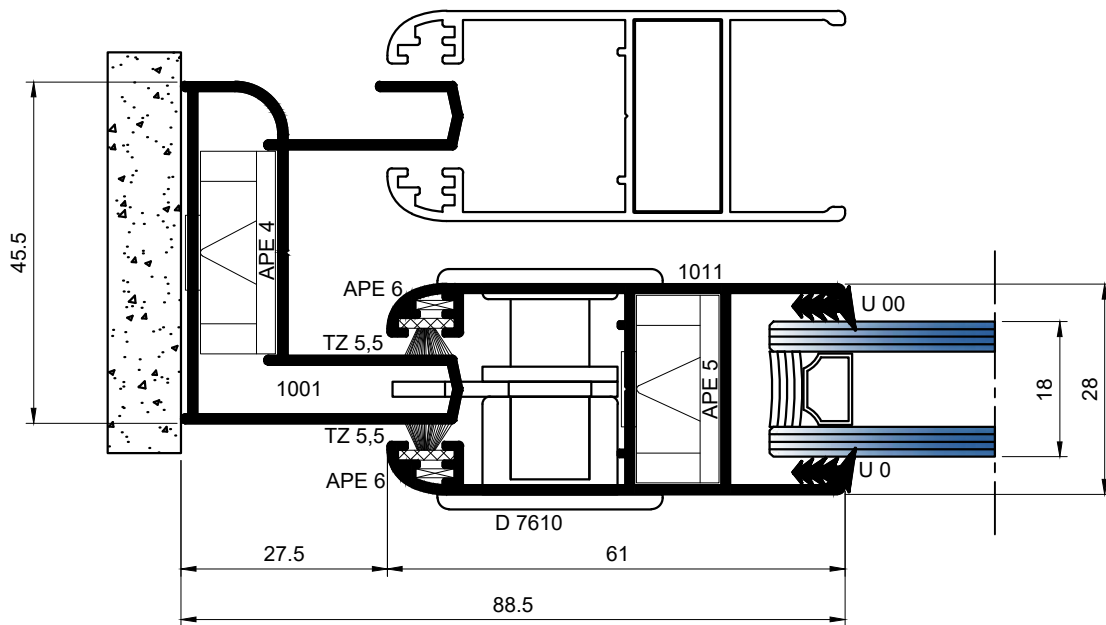
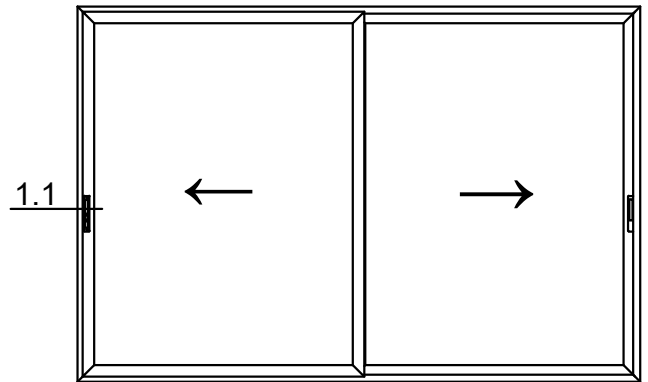

1.1 DETAILS

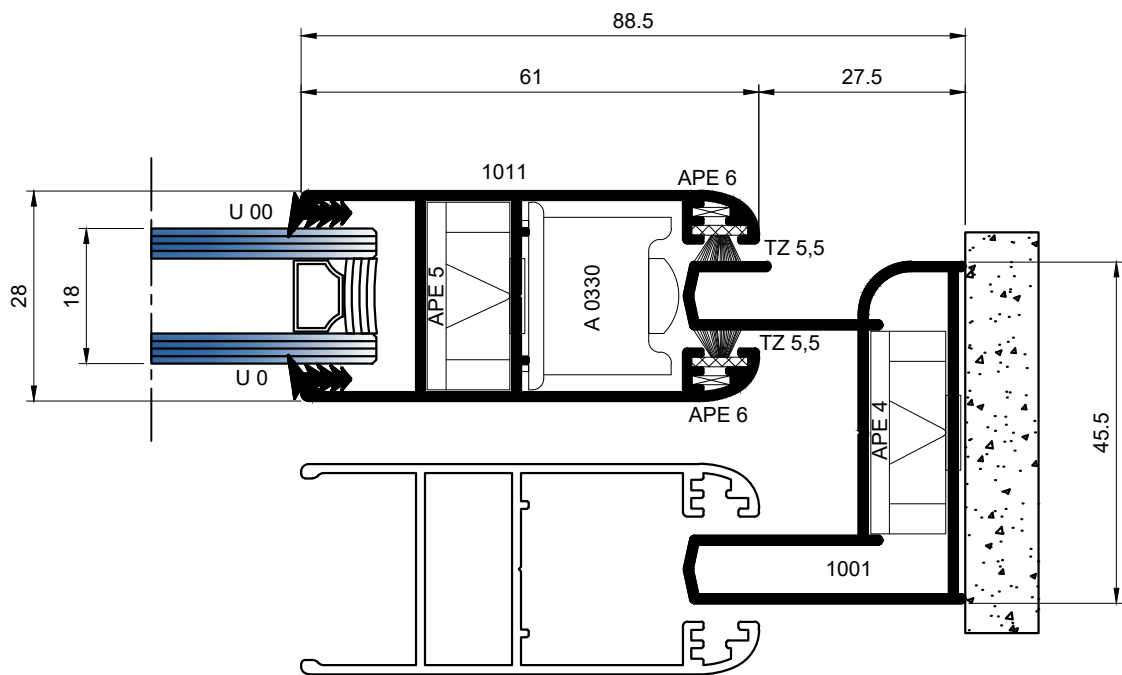
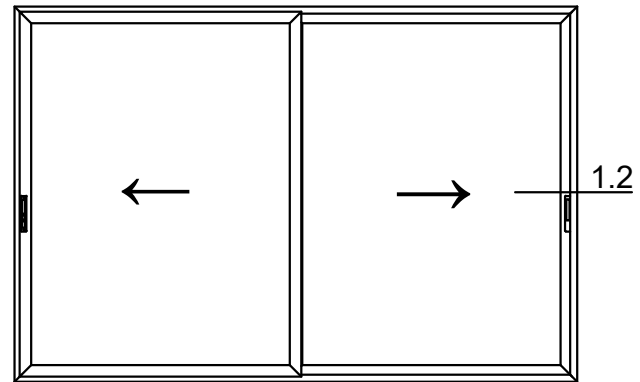

1.2 DETAILS

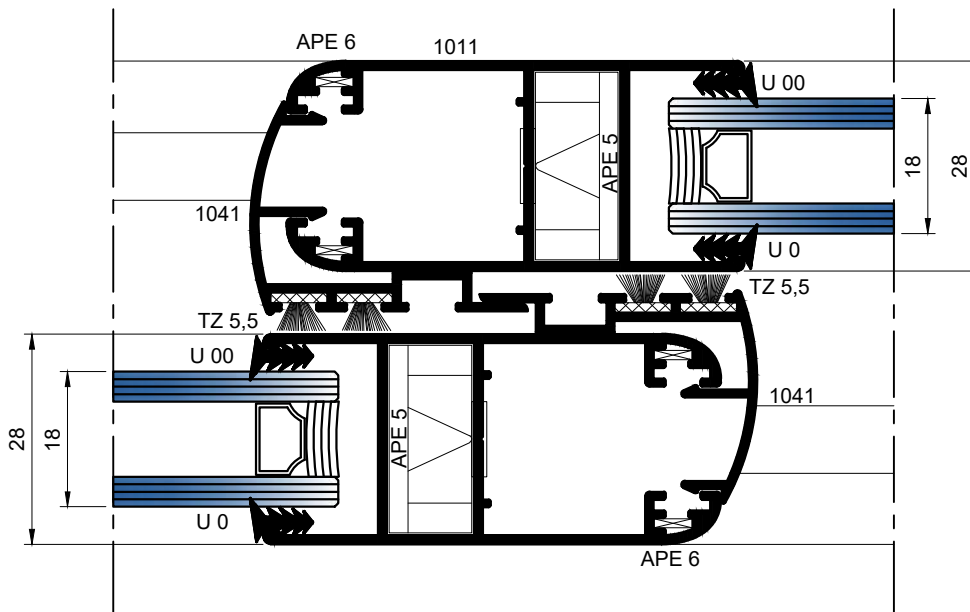
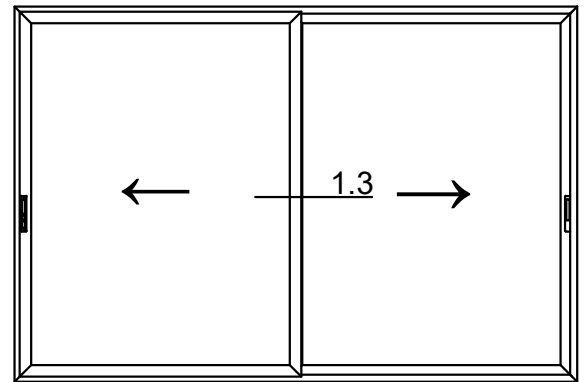

1.3 DETAILS

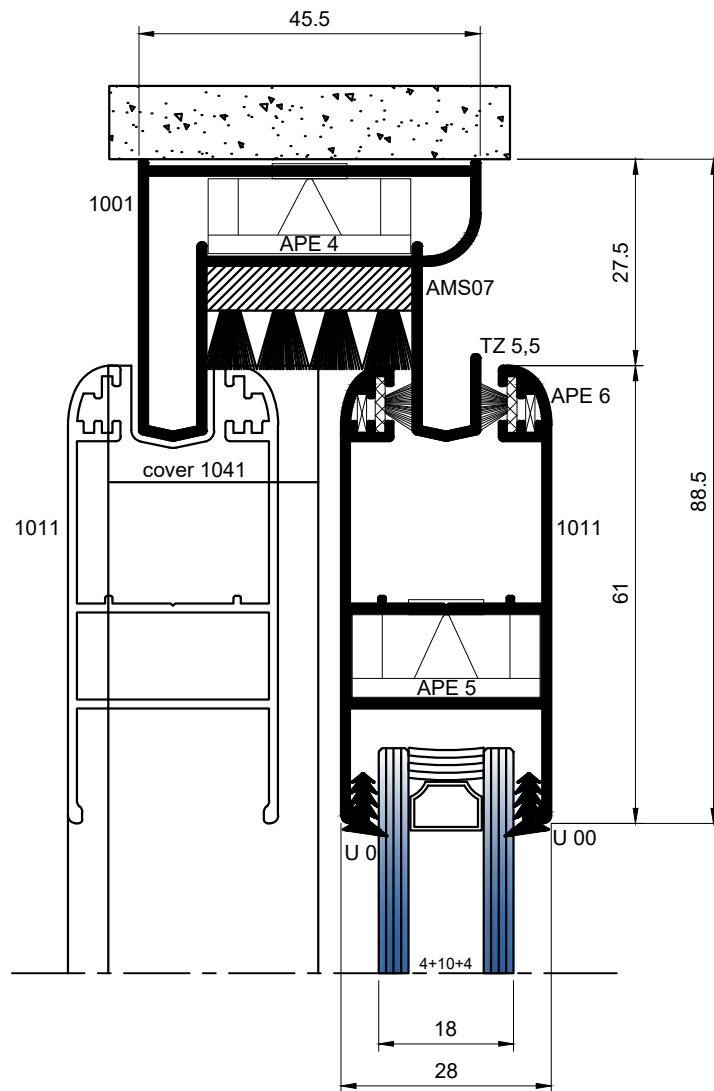
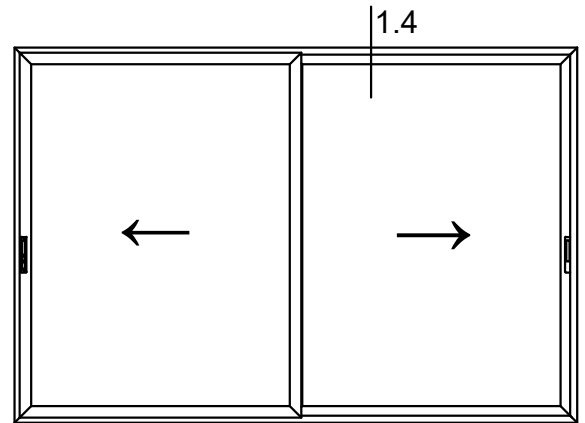

1.4 DETAILS

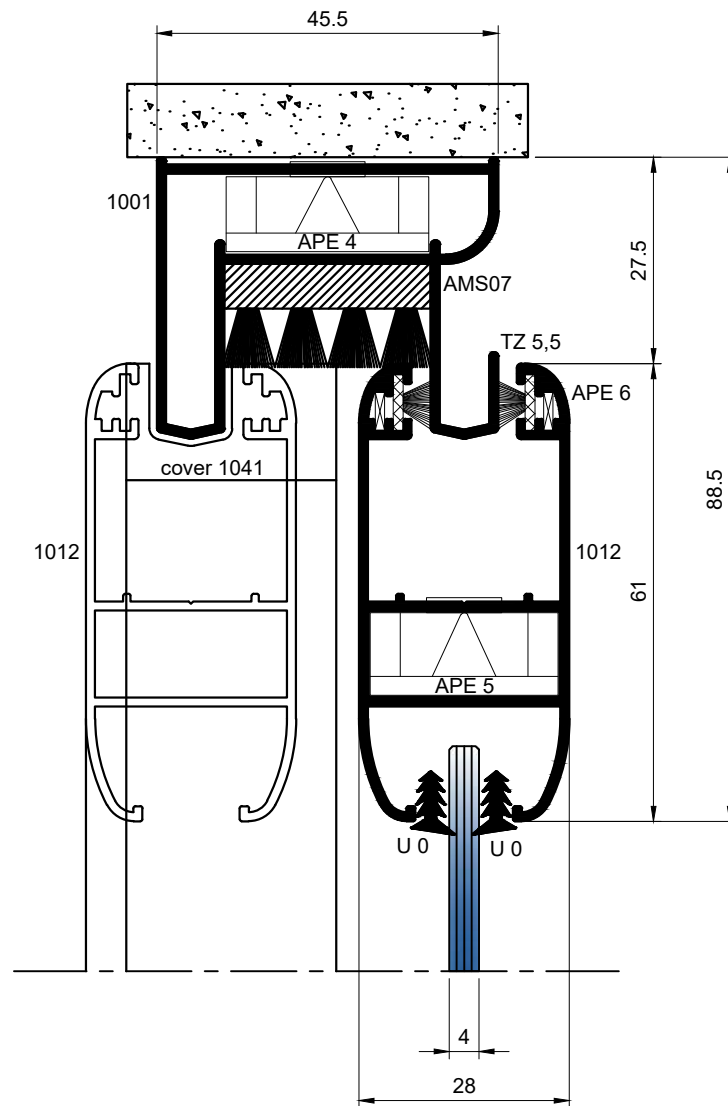
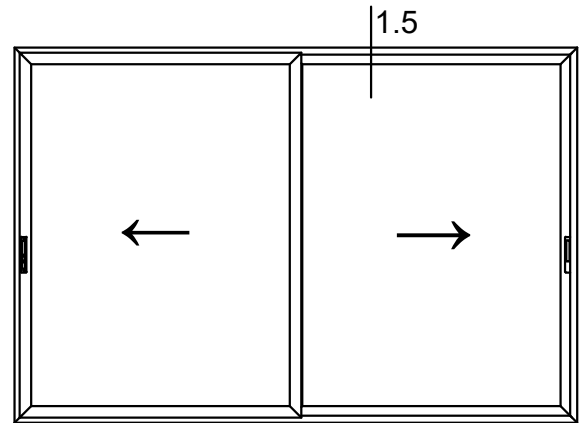

1.5 DETAILS

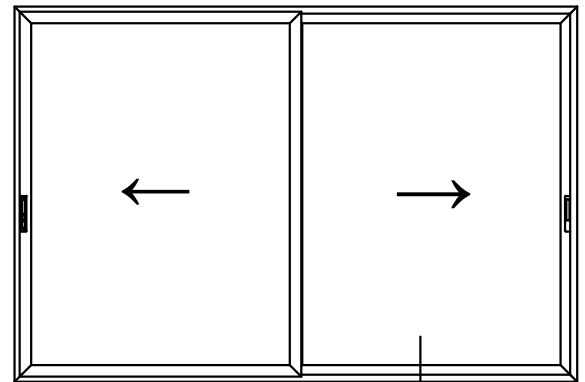

1.6

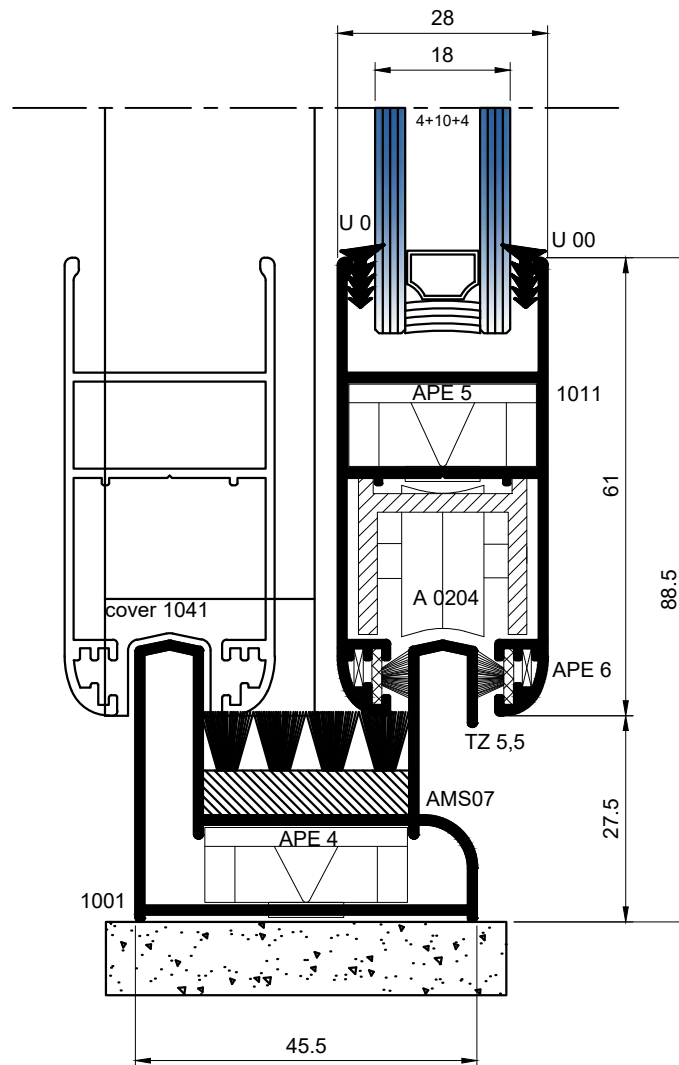

1.6 DETAILS

1.2

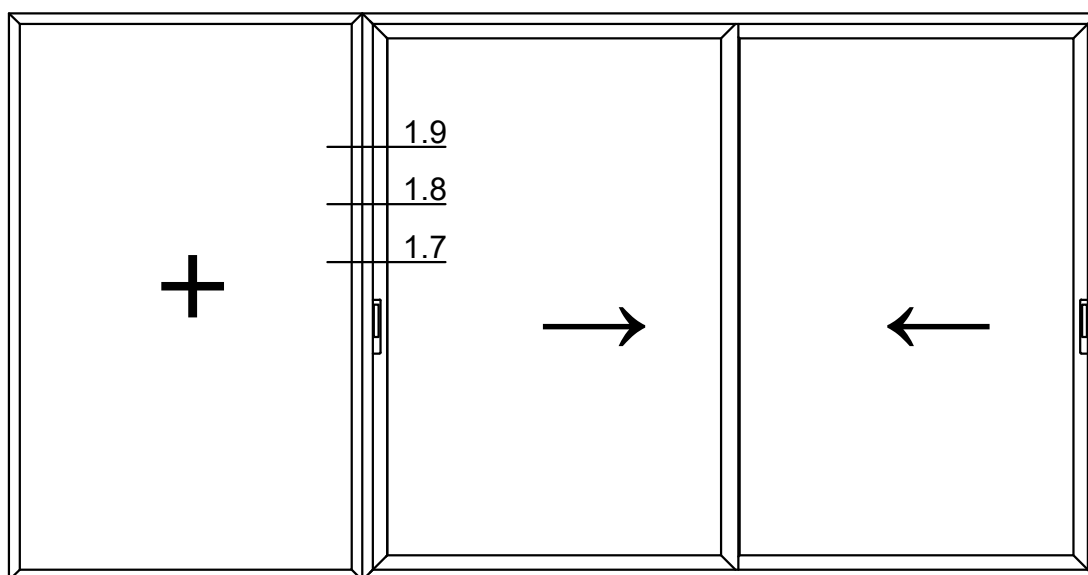

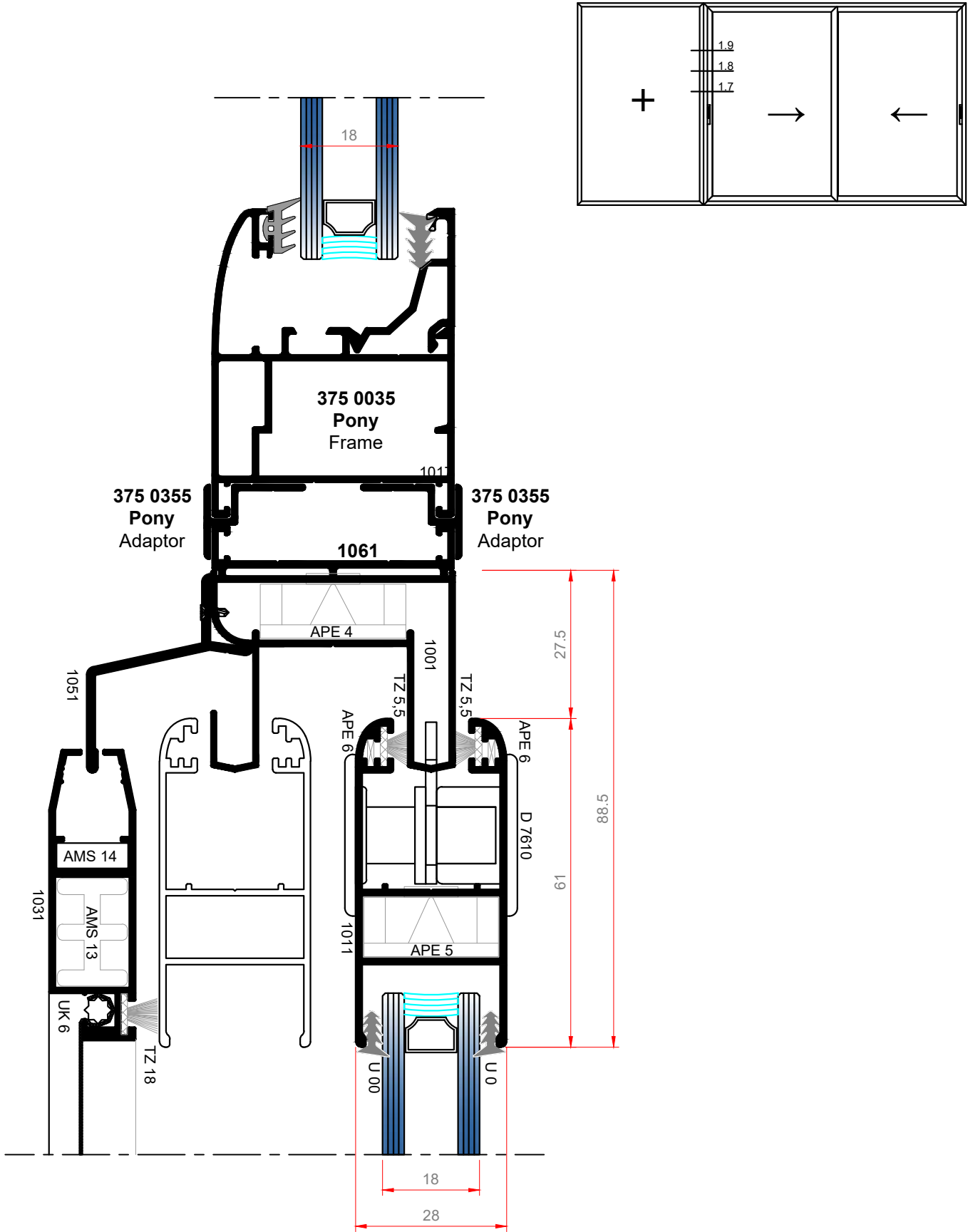

1.7 DETAILS

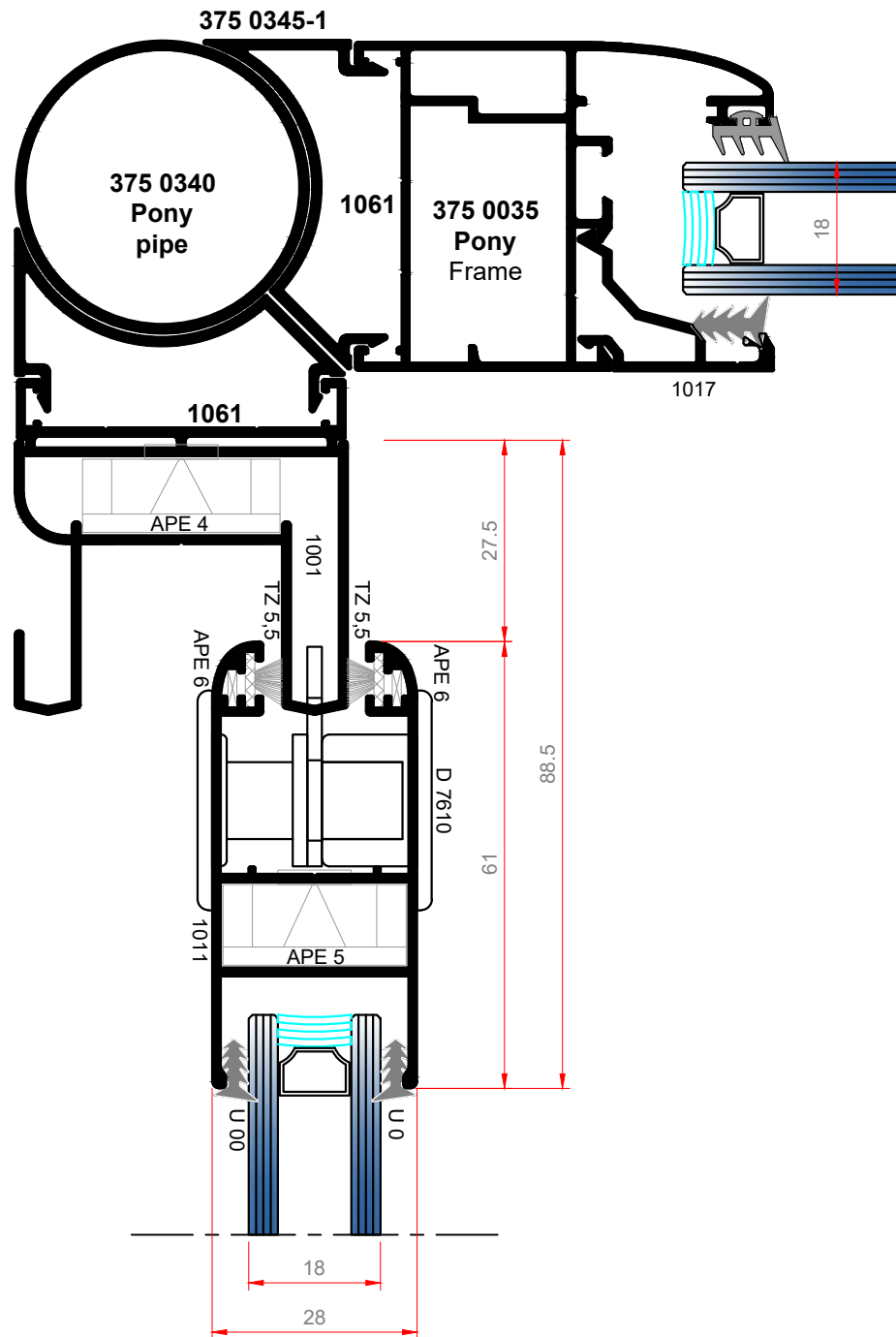
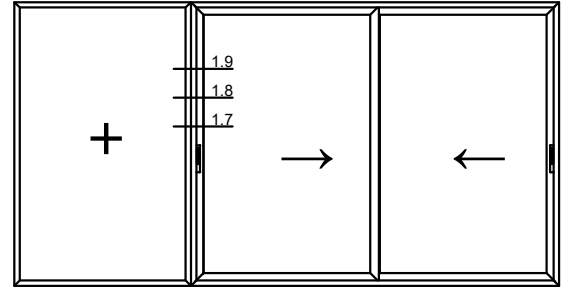

1.7 DETAILS

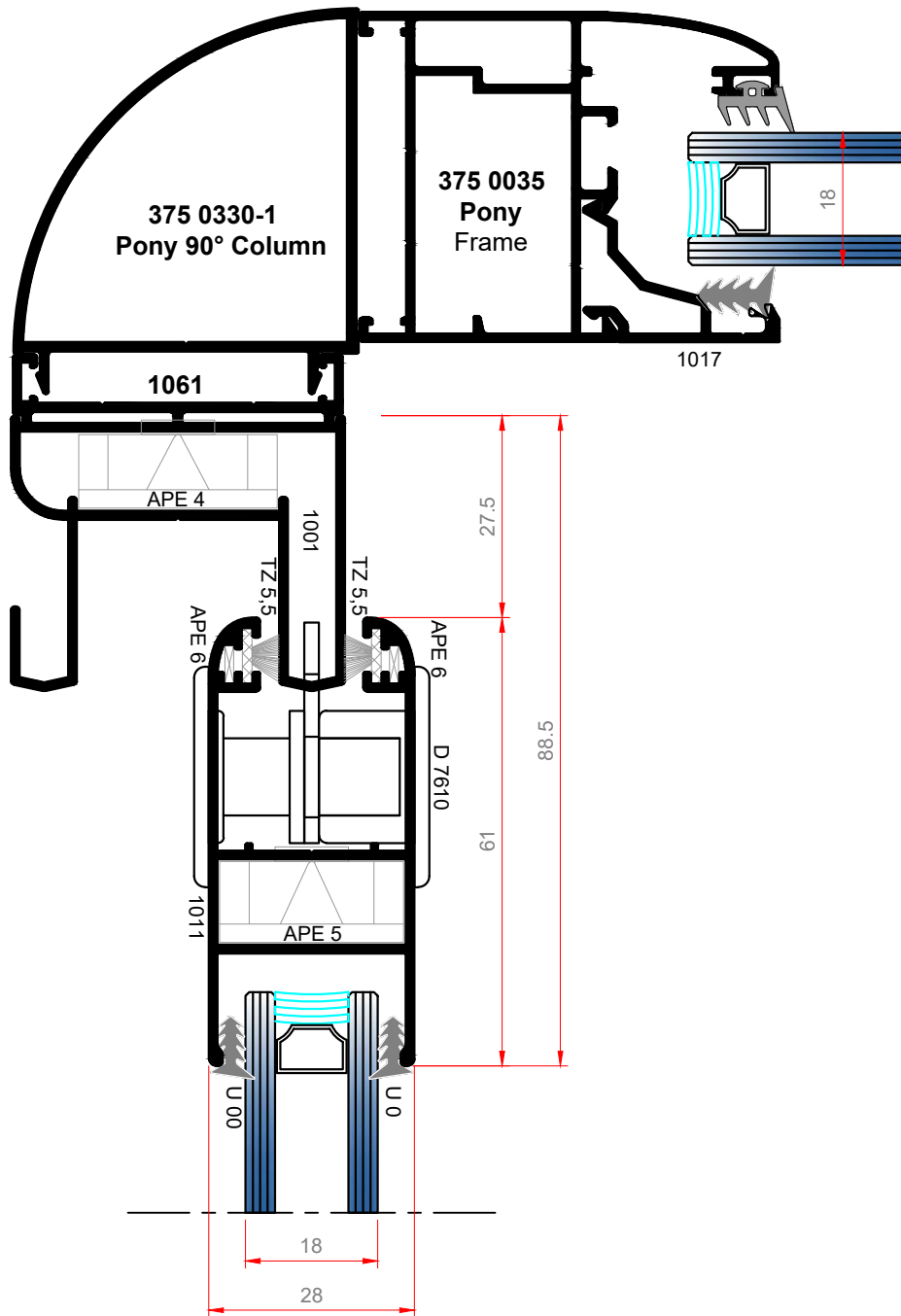
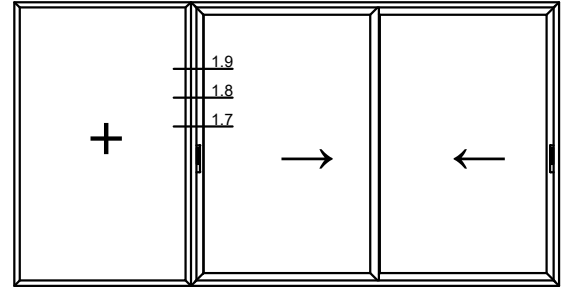

1.8 DETAILS

2

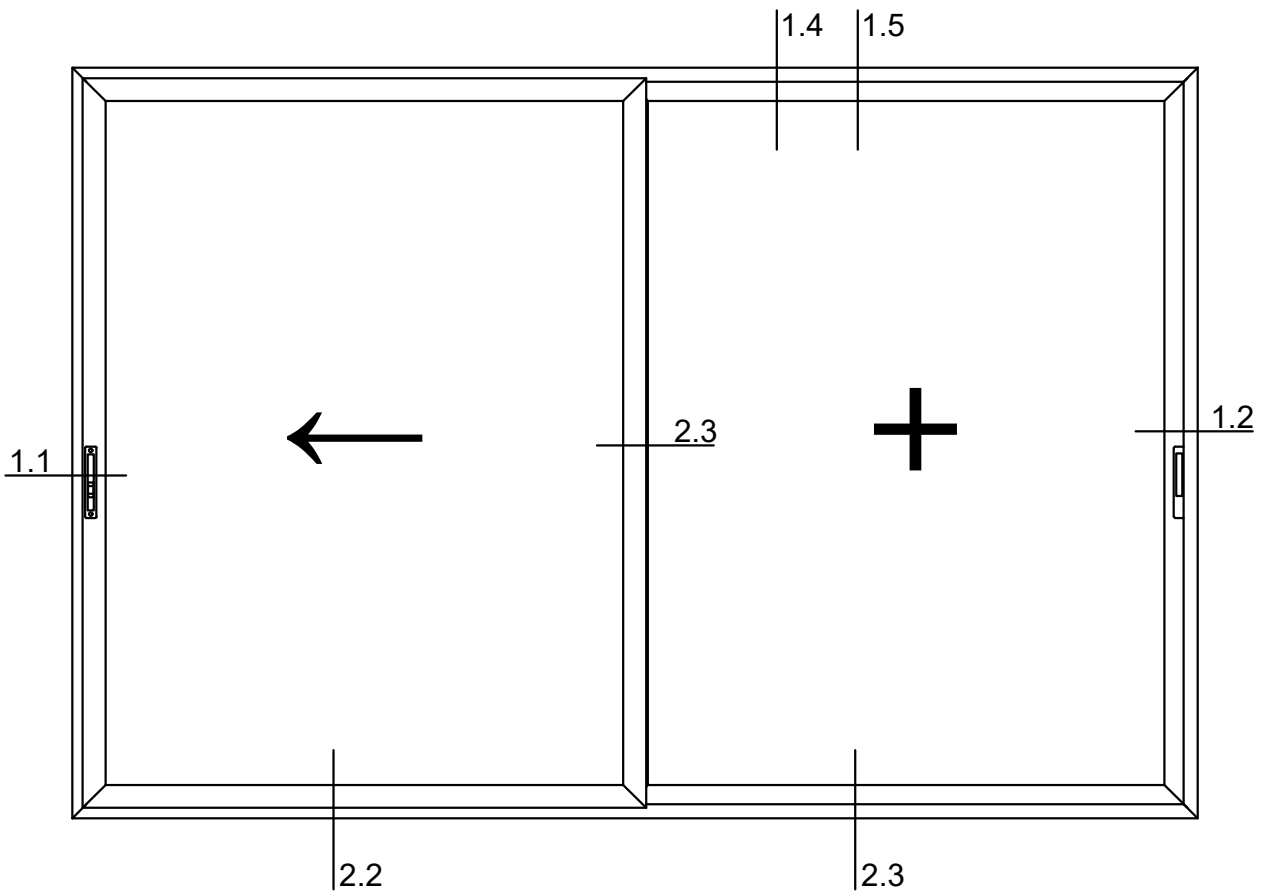

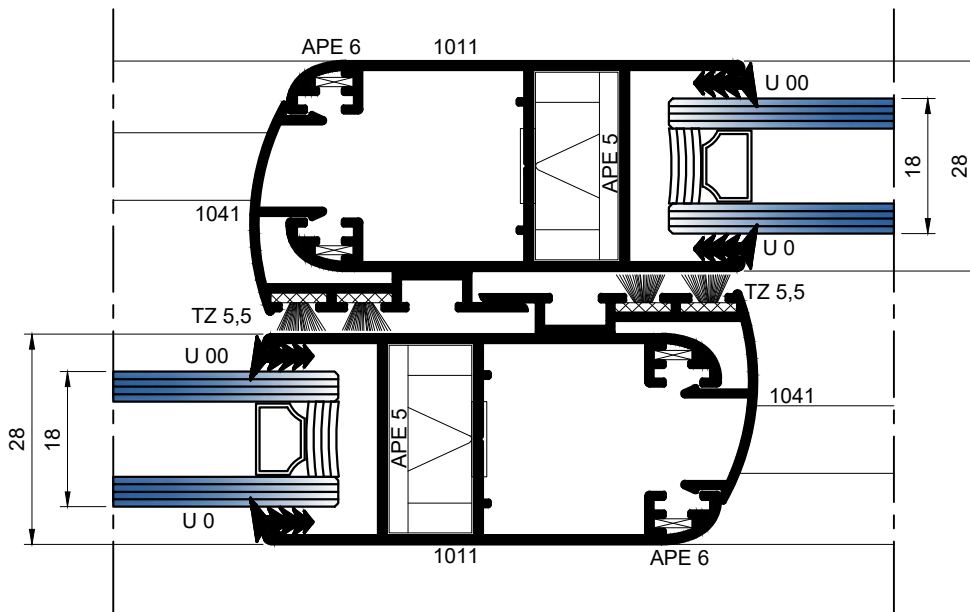
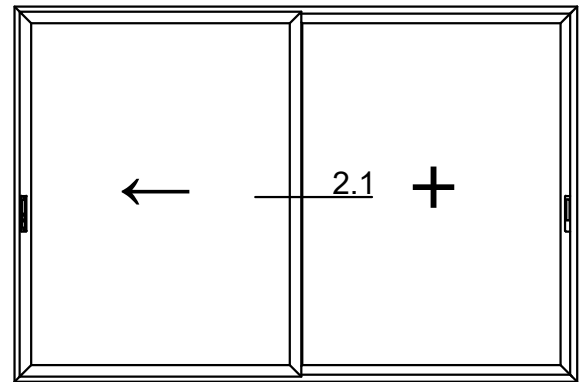

2.1 DETAILS

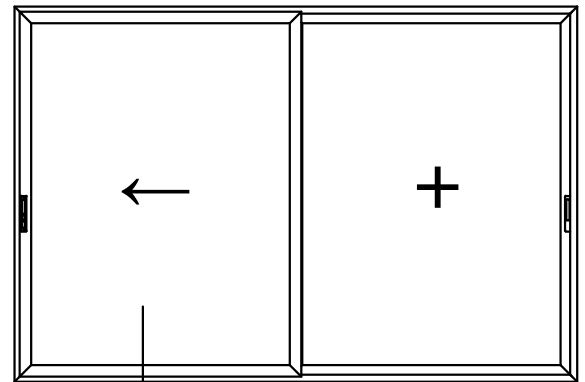

2.2

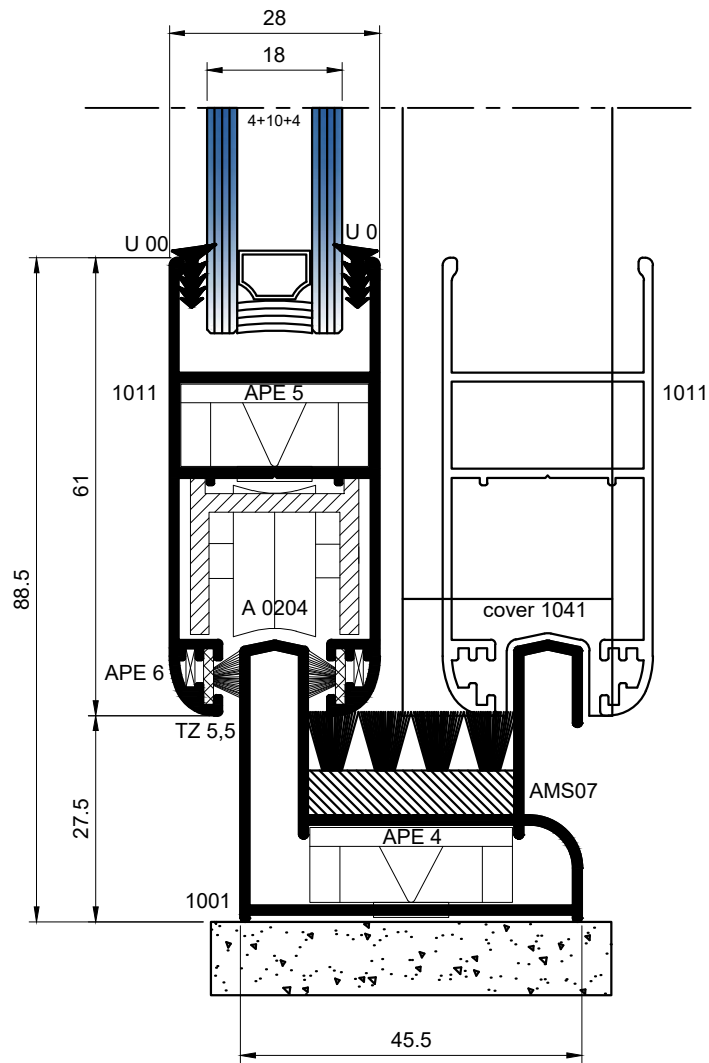

2.2 DETAILS

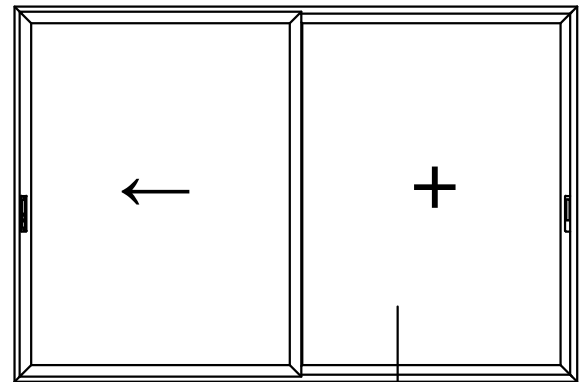

2.3

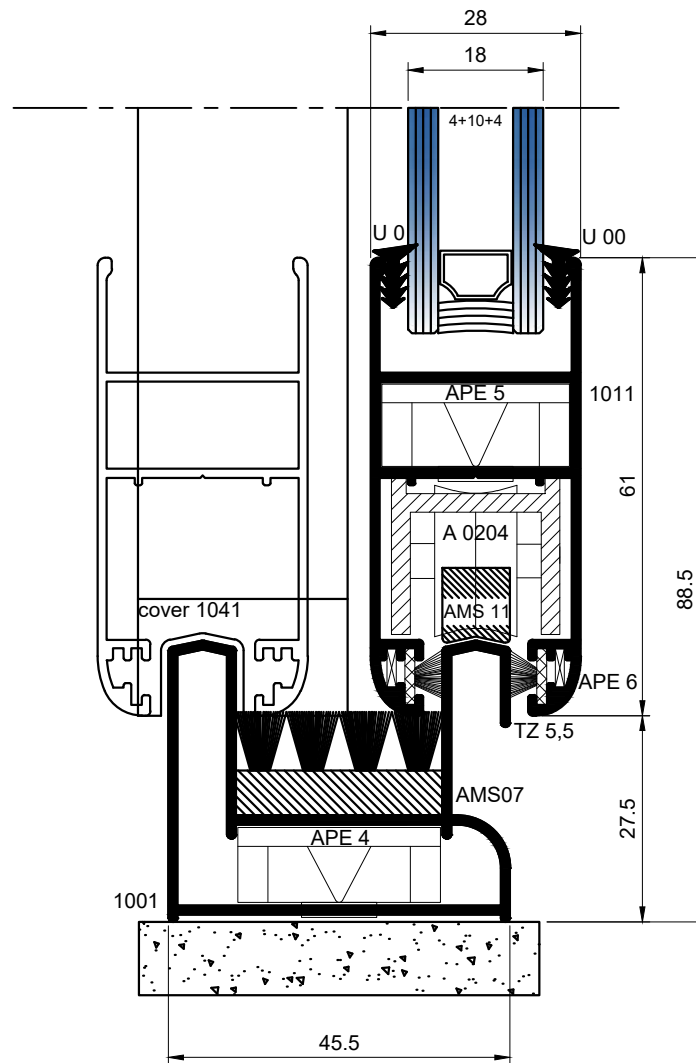

2.3 DETAILS

3

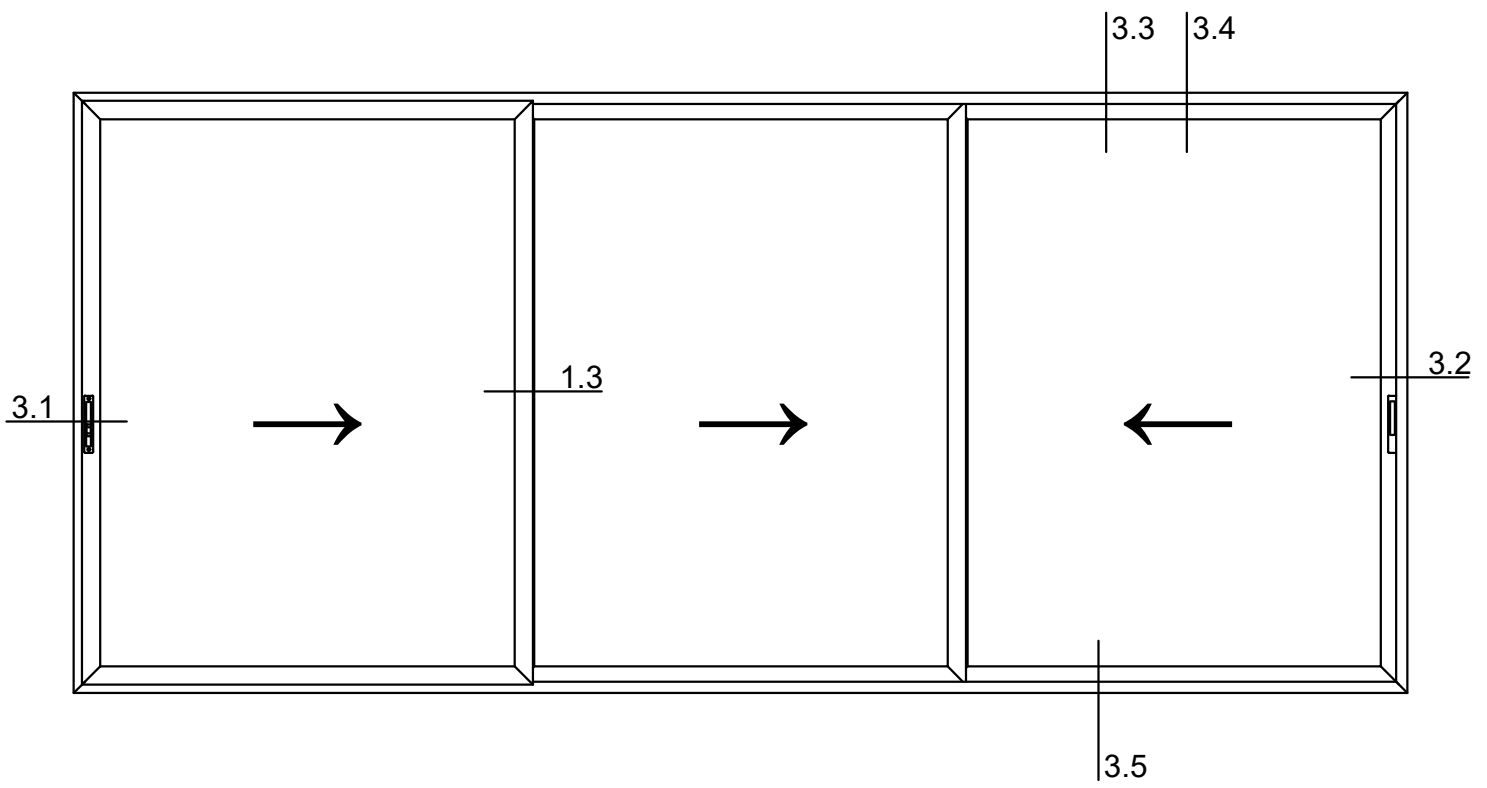

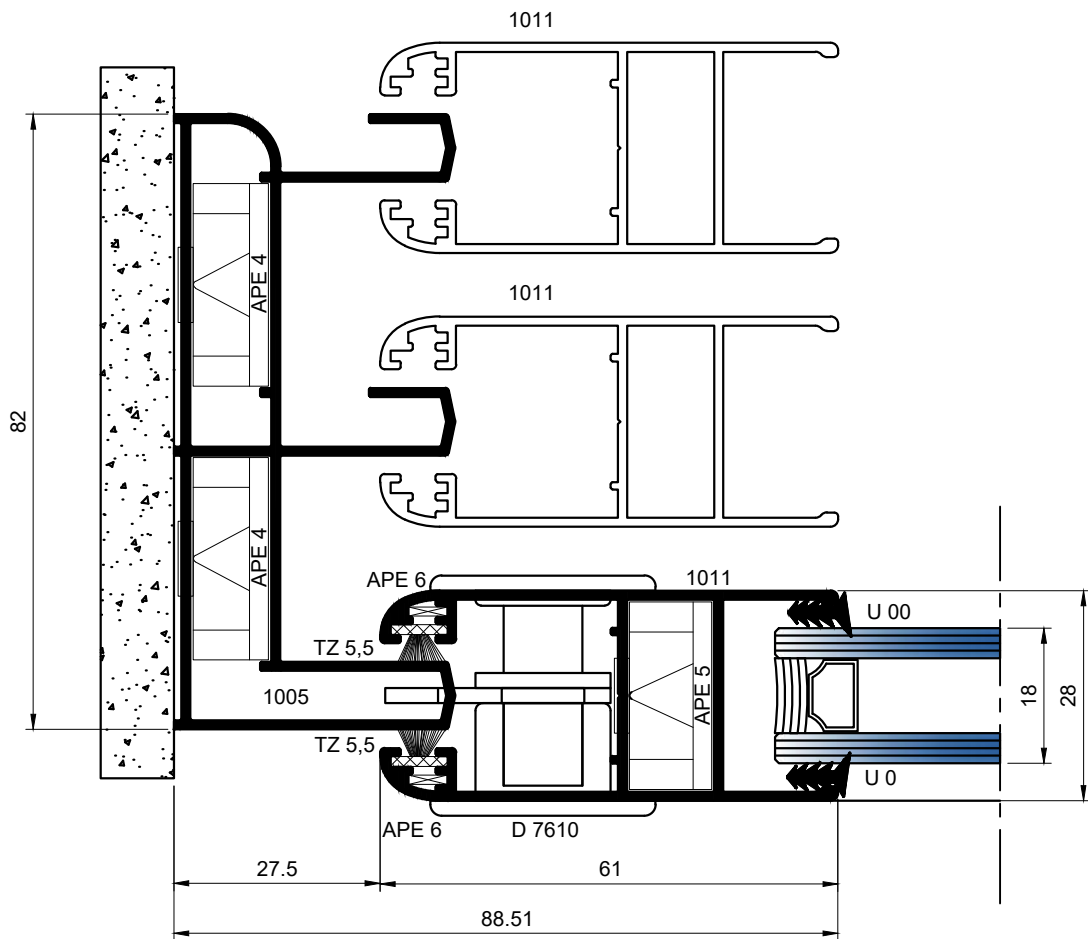
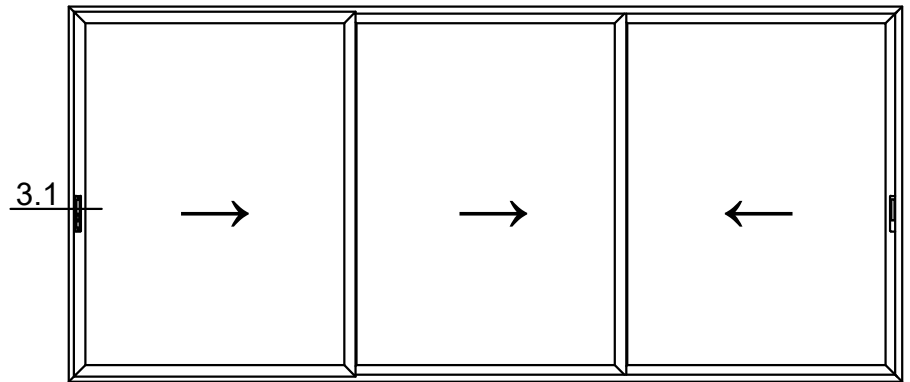

APE 6

3.1 DETAILS

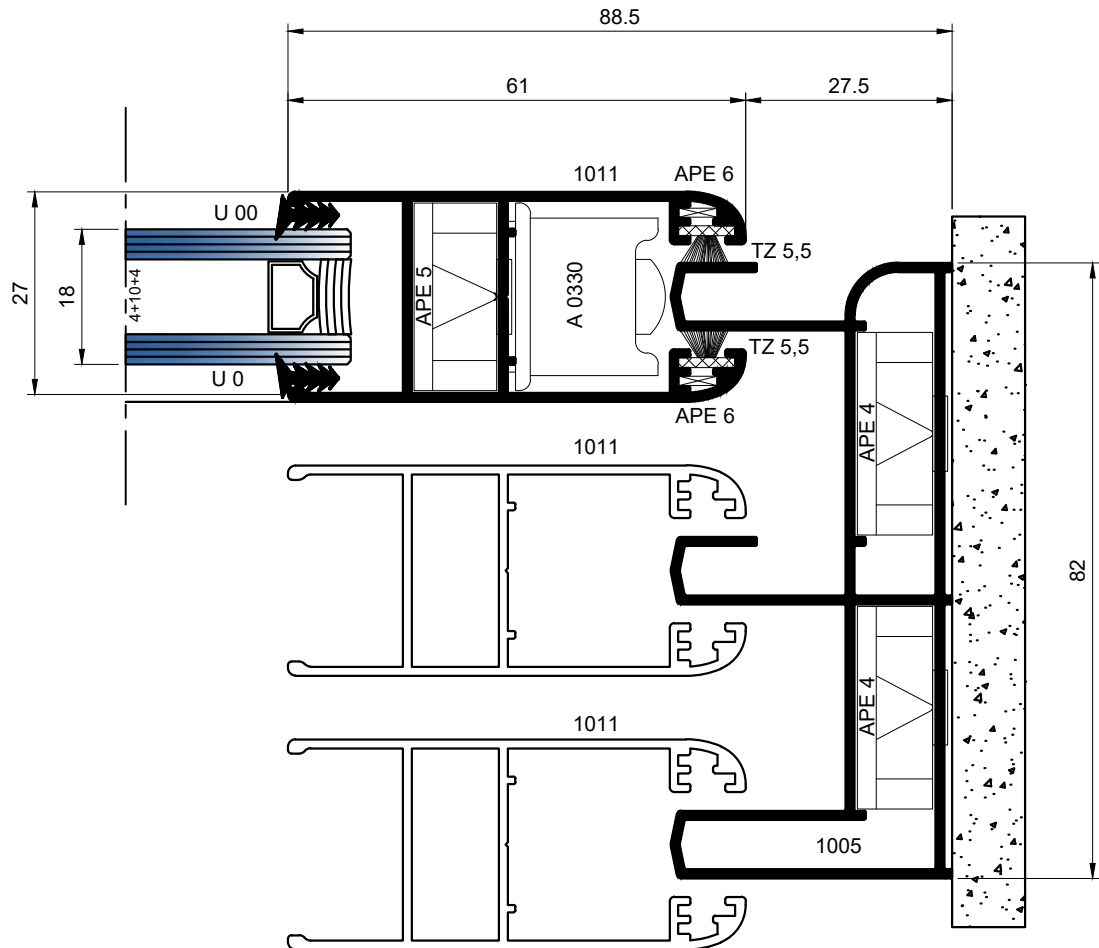
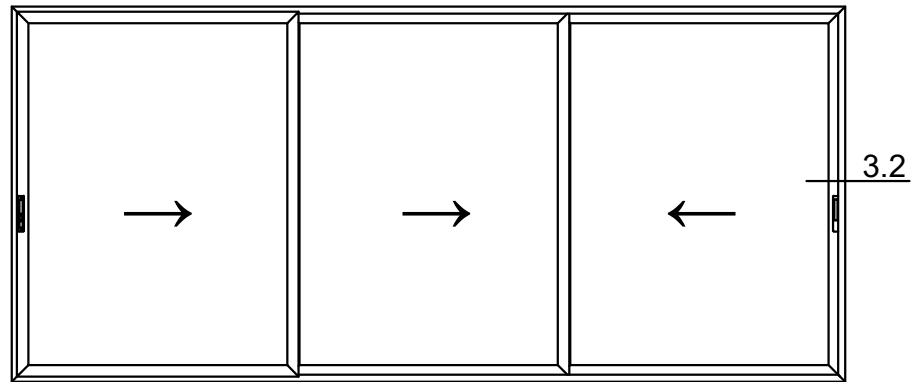

3.2 DETAILS

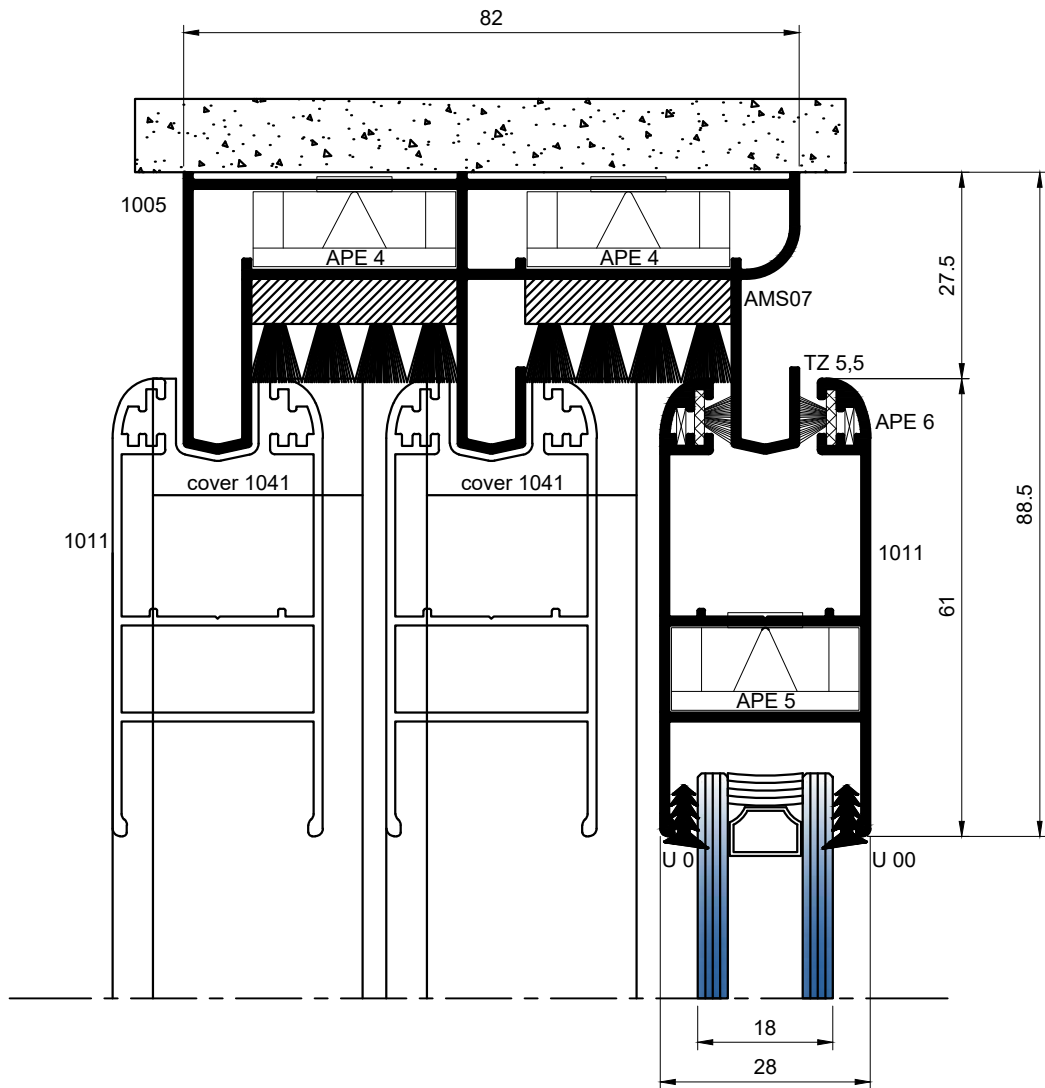
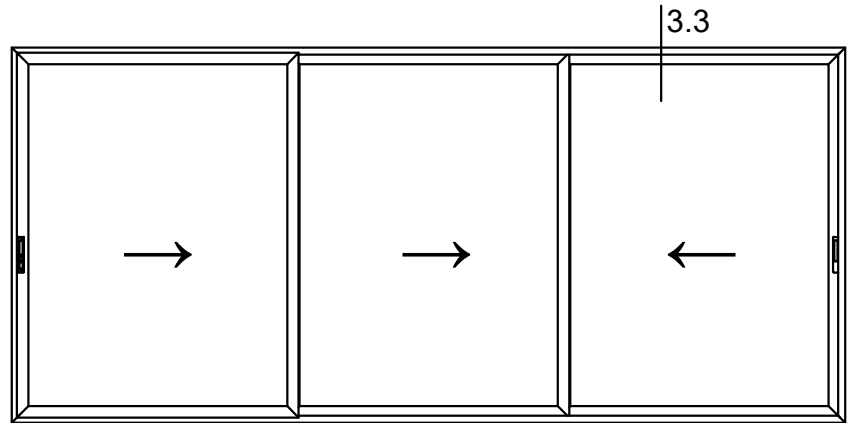

3.3 DETAILS

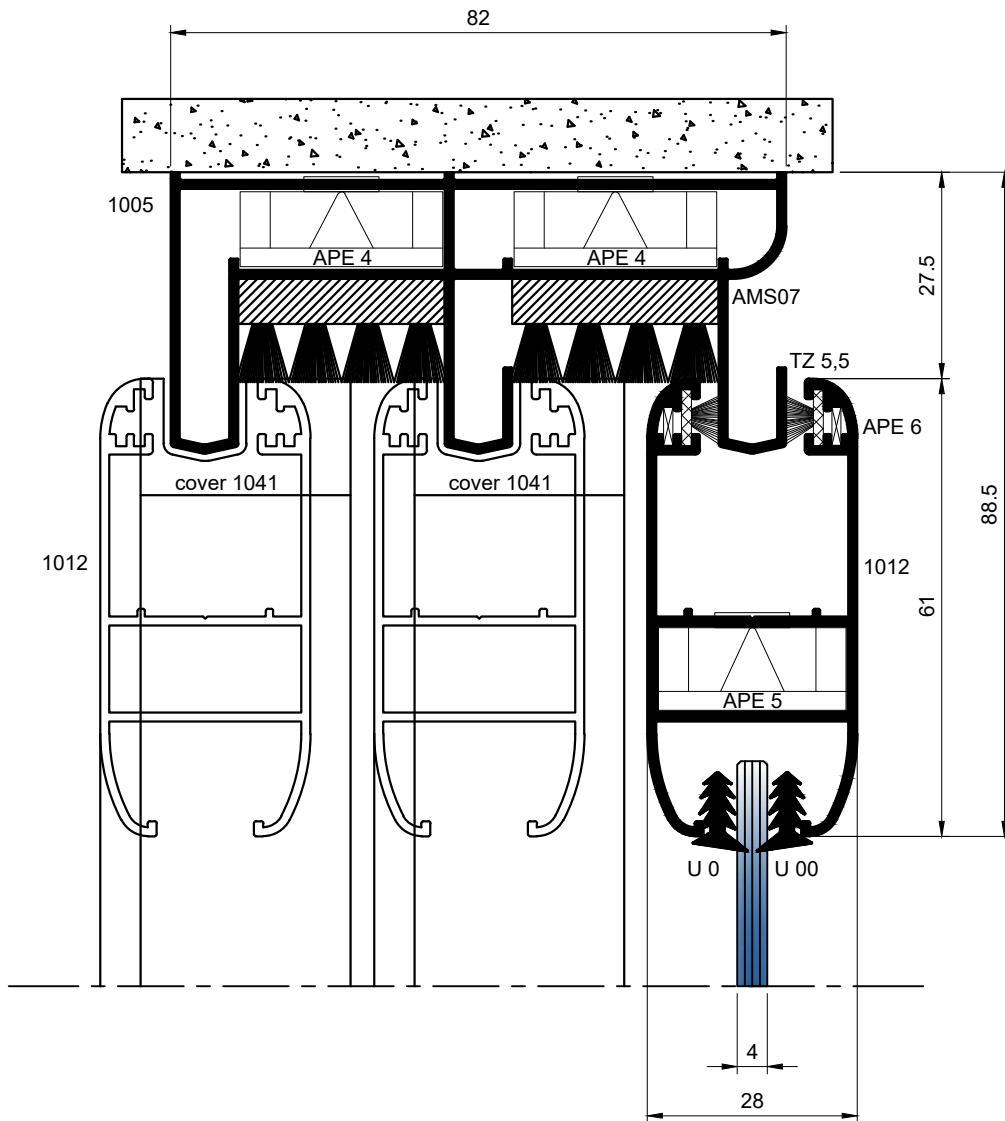
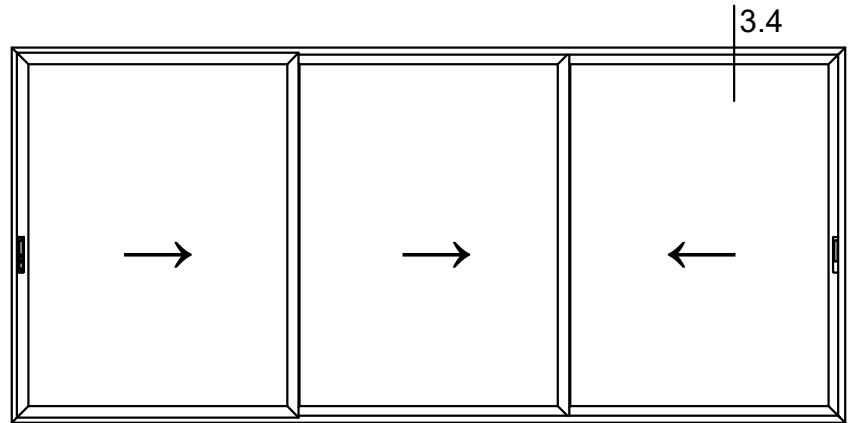

3.4 DETAILS

4

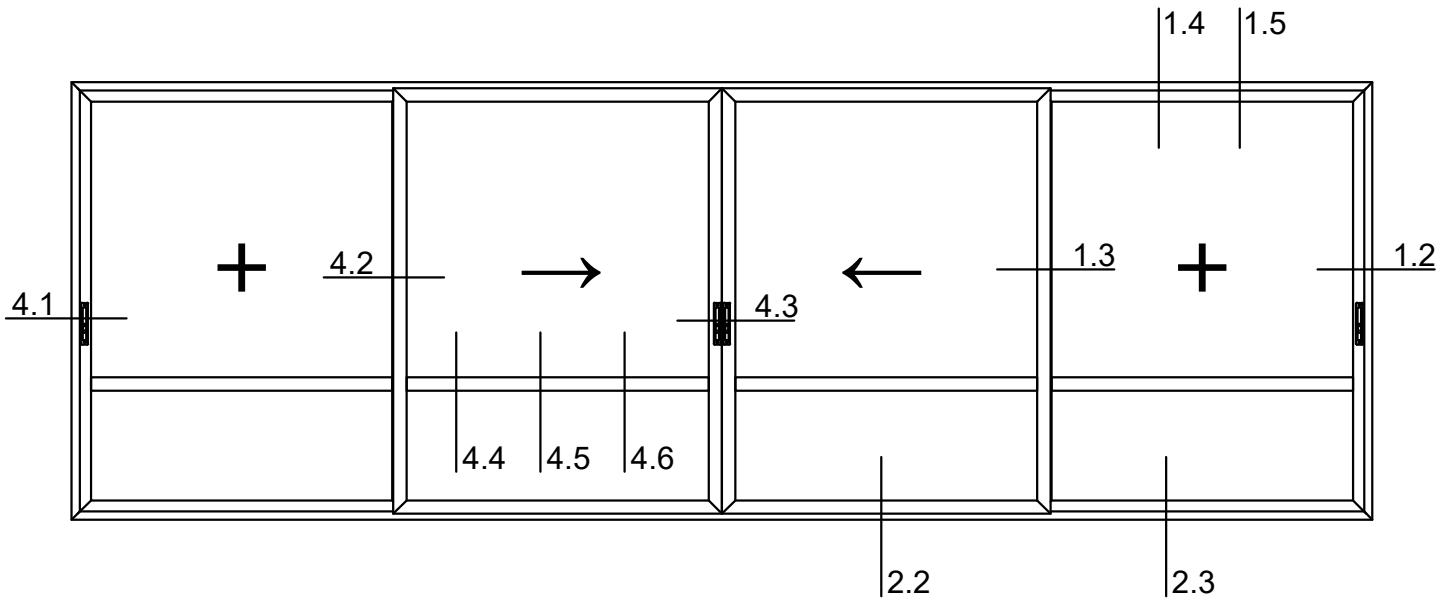

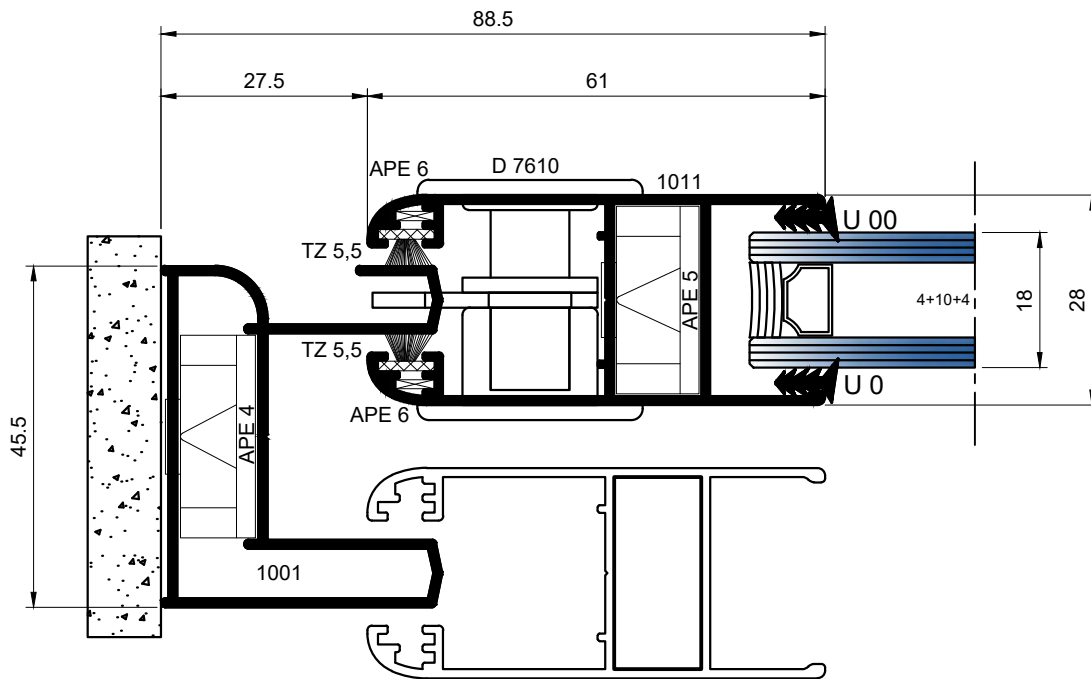
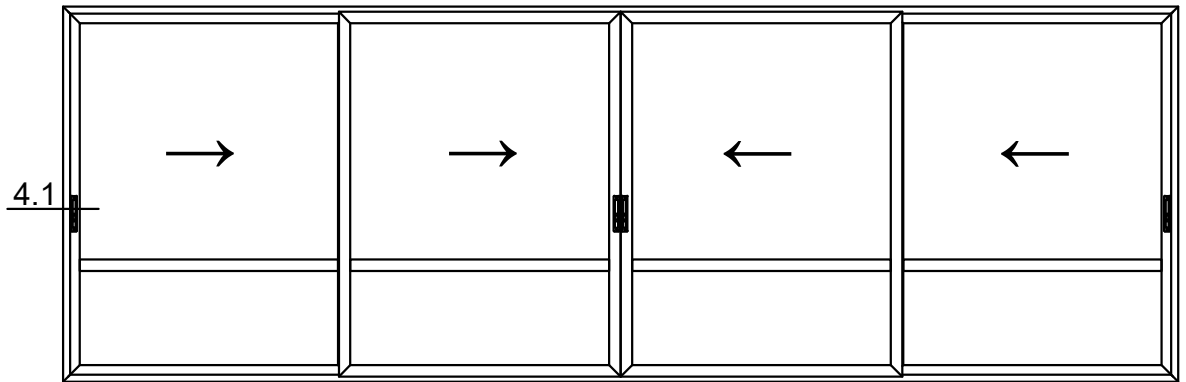

4.1 DETAILS

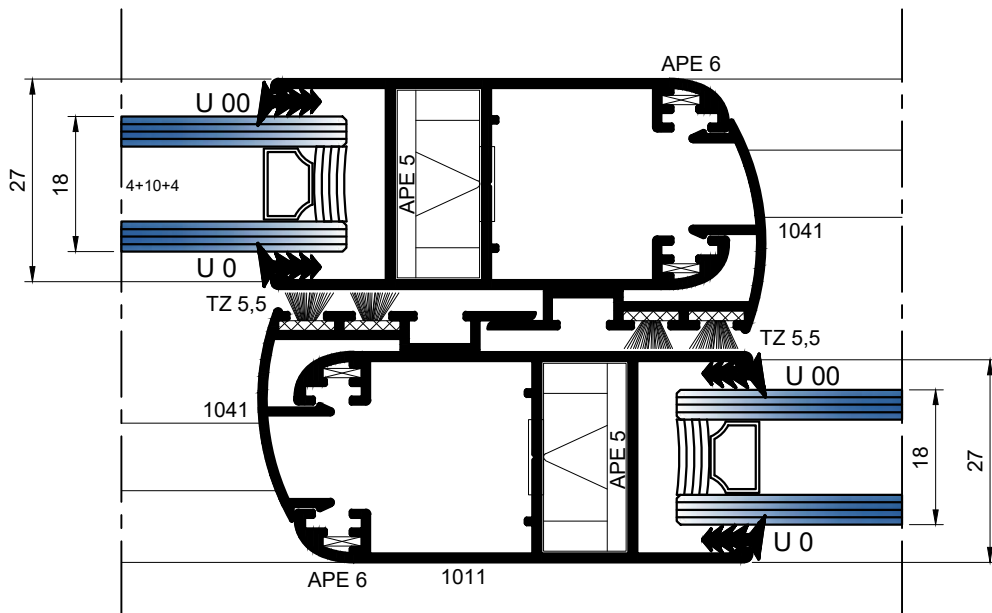
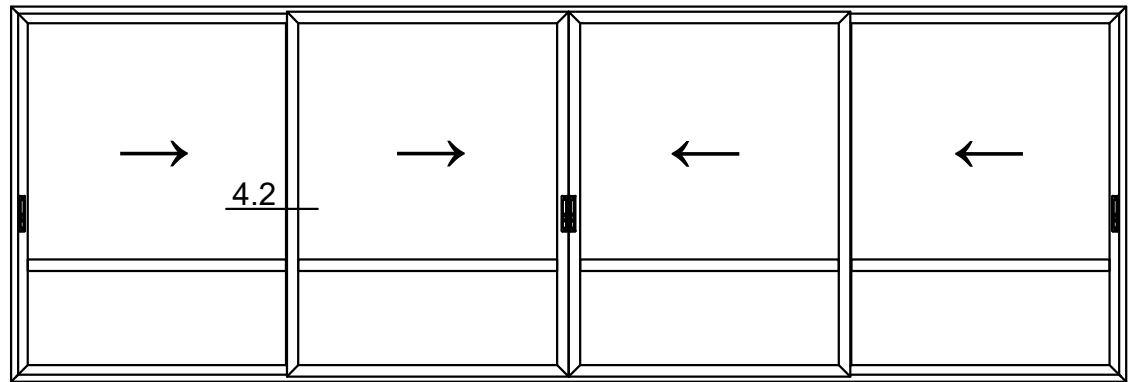

4.2 DETAILS

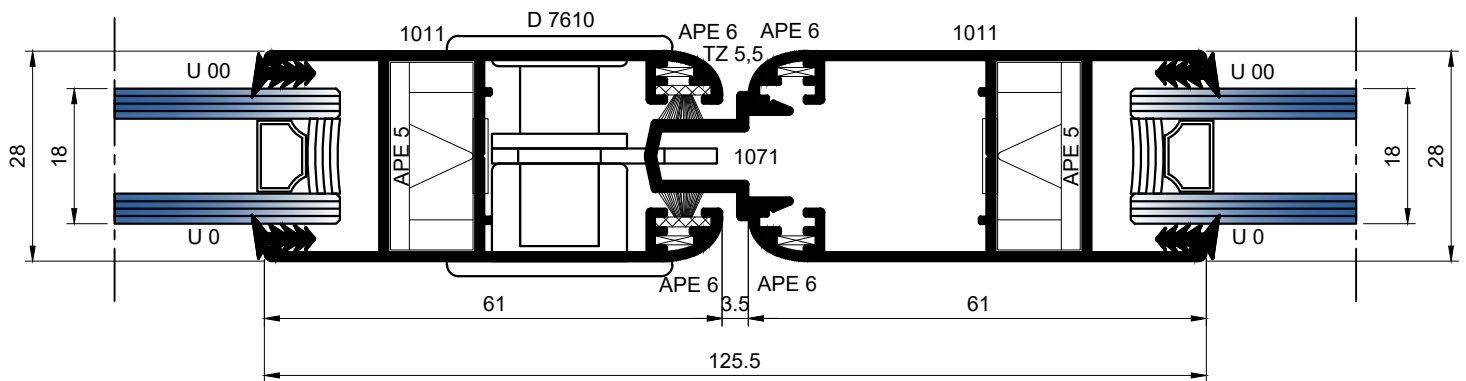
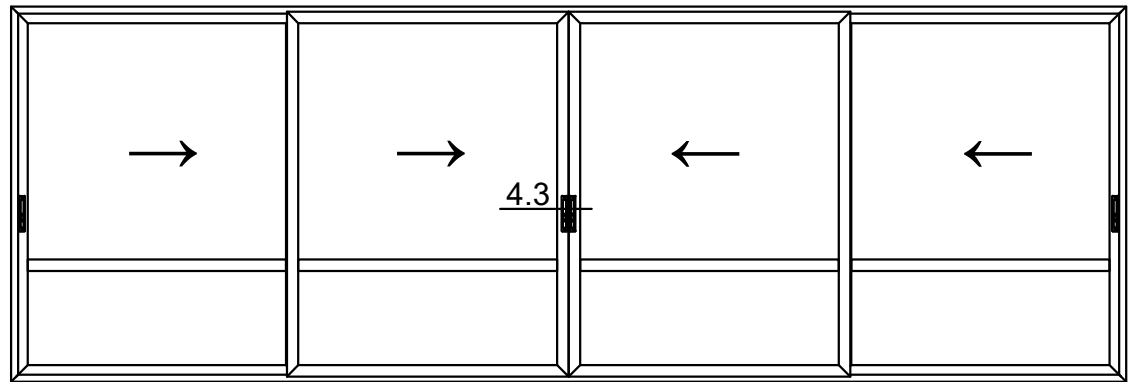

4.3 DETAILS

MINI SLIDING SYSTEM

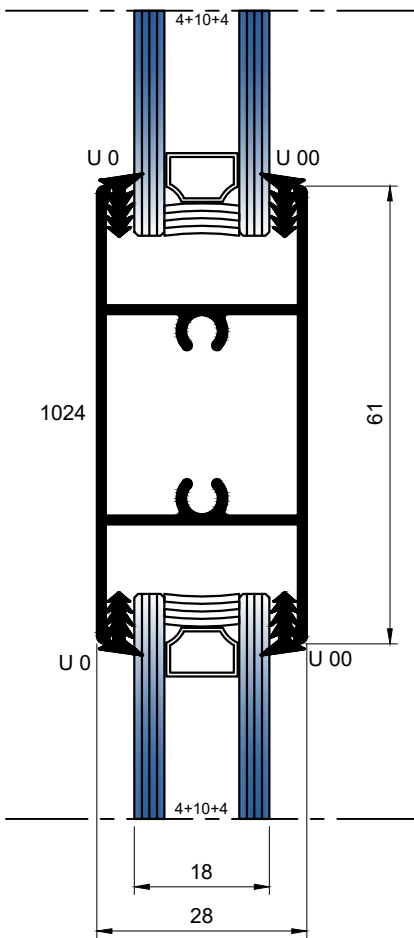
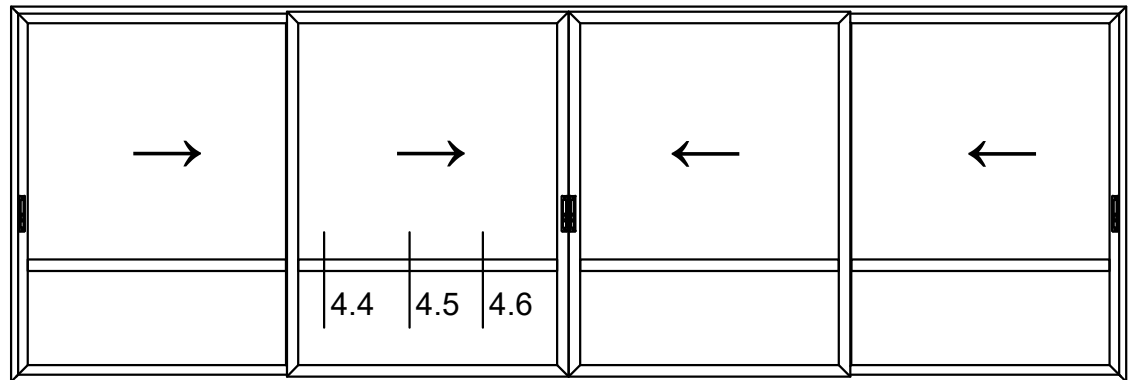

4.4 DETAILS

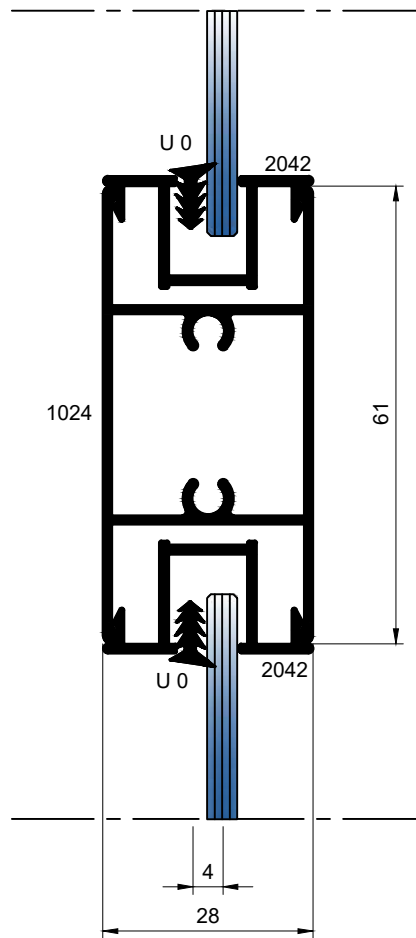

4.5 DETAILS

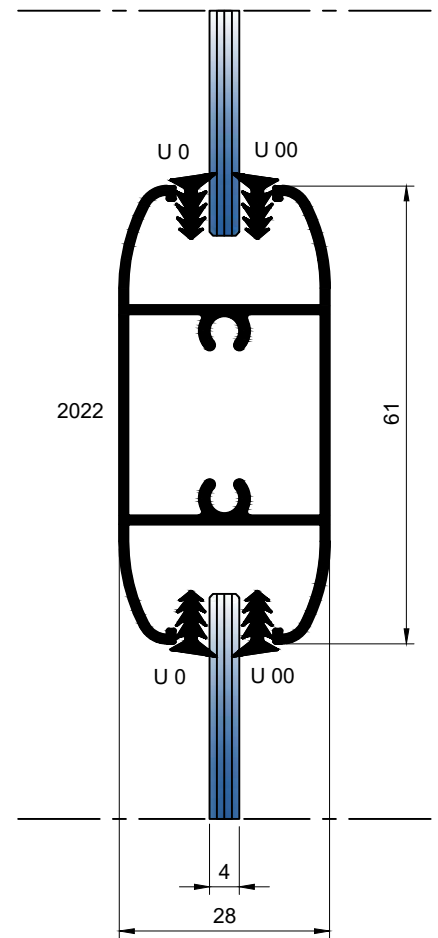

4.6 DETAILS

5

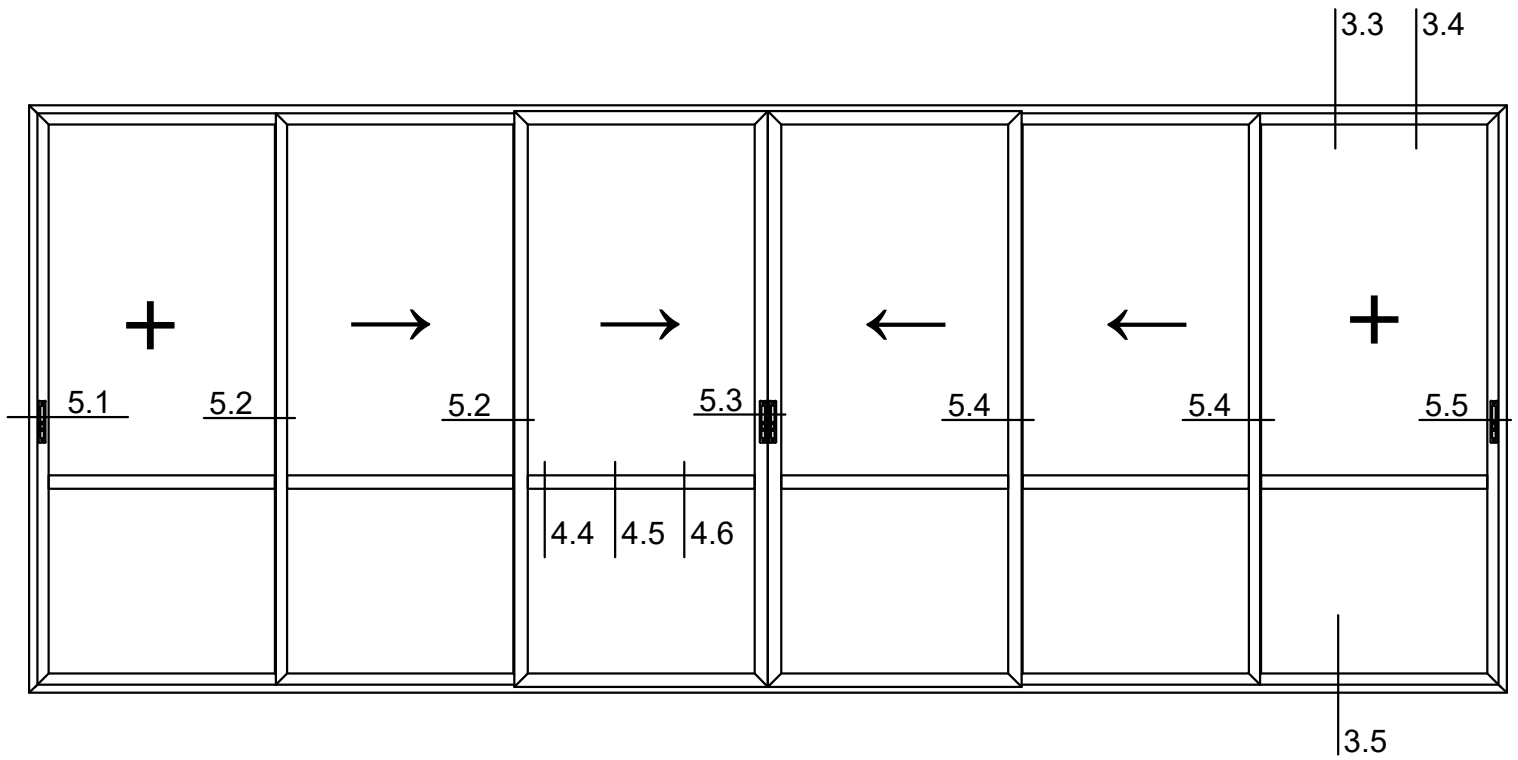

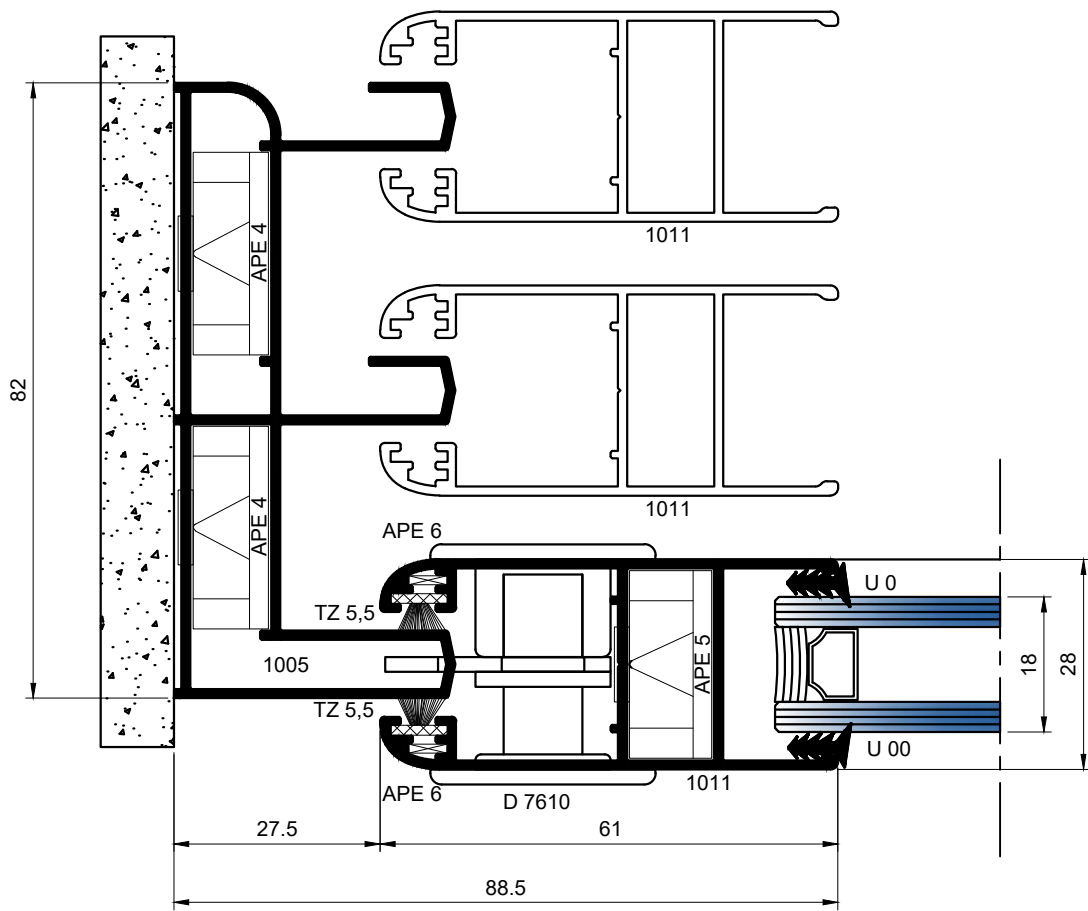
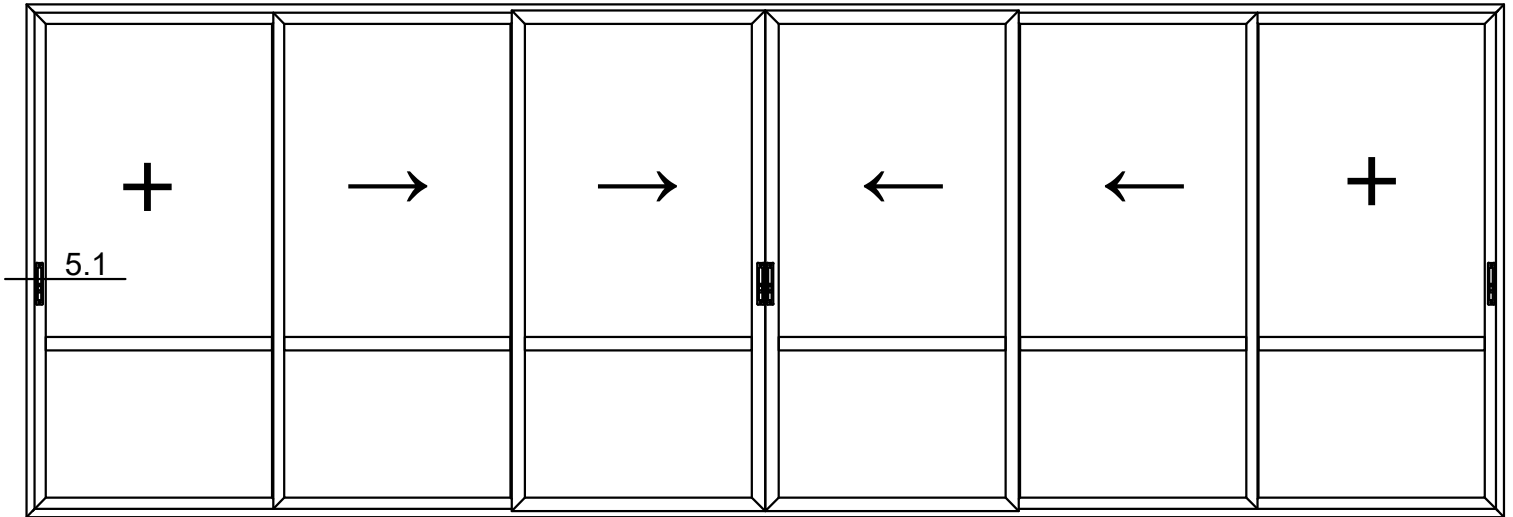

5.1 DETAILS

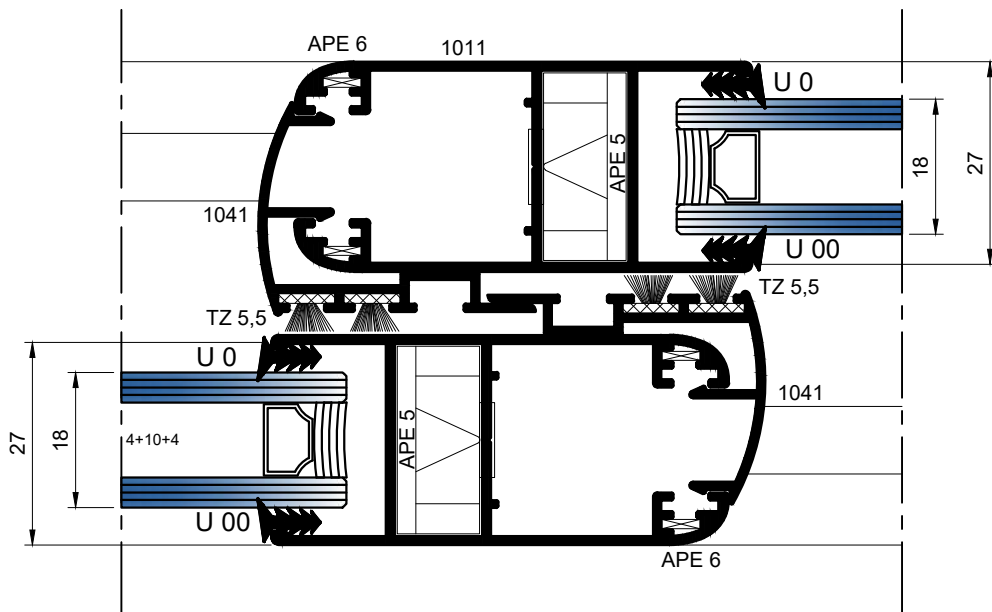
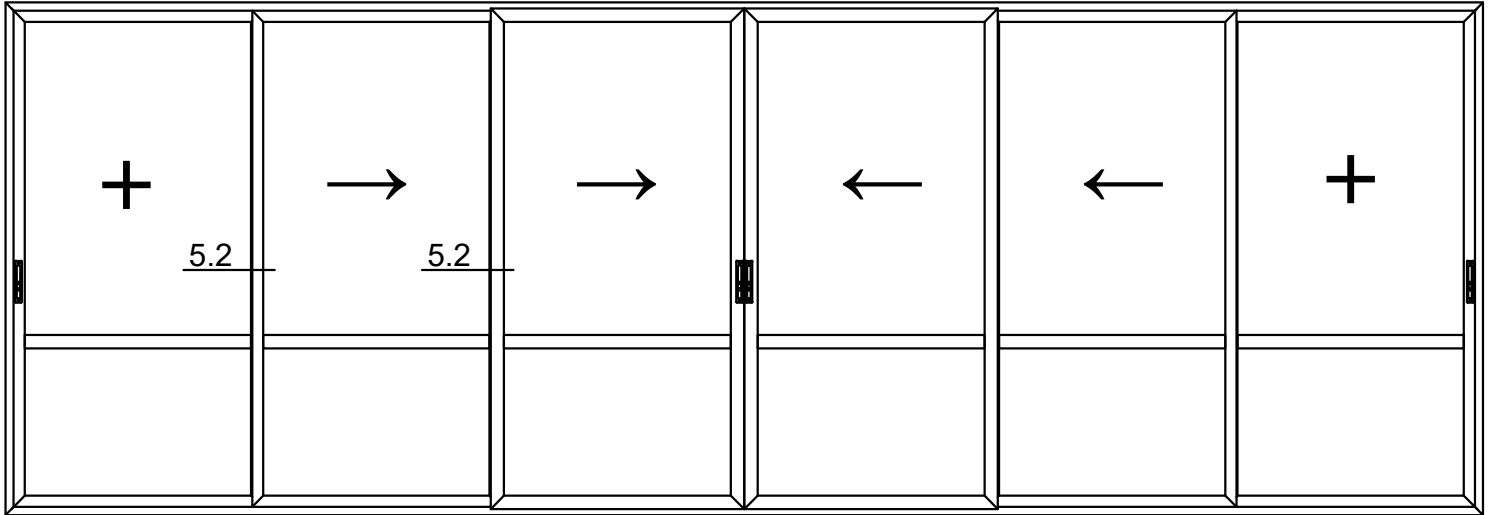

5.2 DETAILS

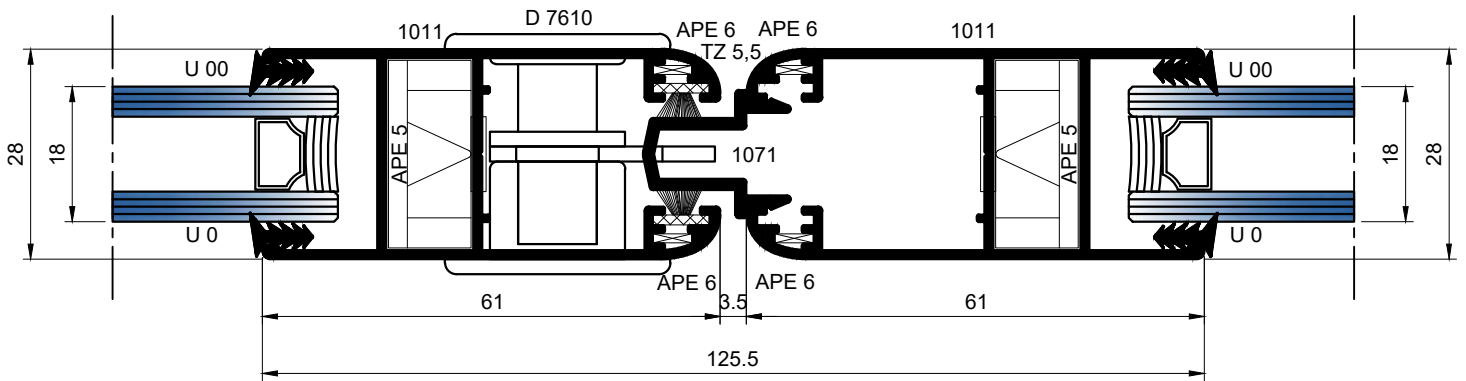
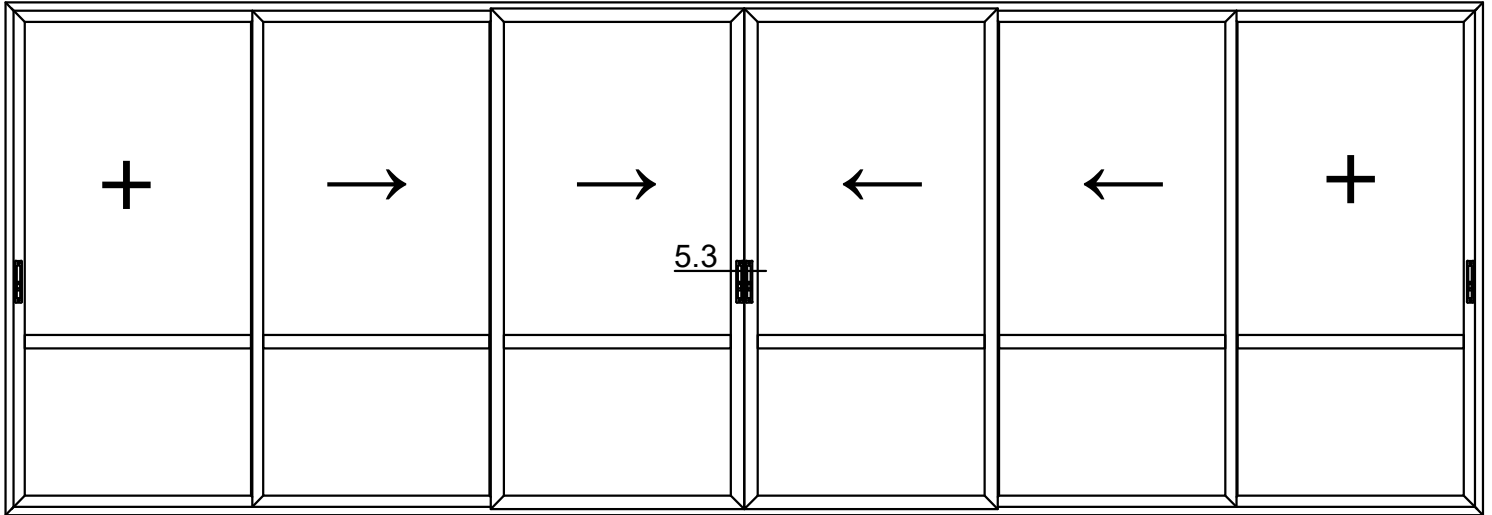

5.3 DETAILS

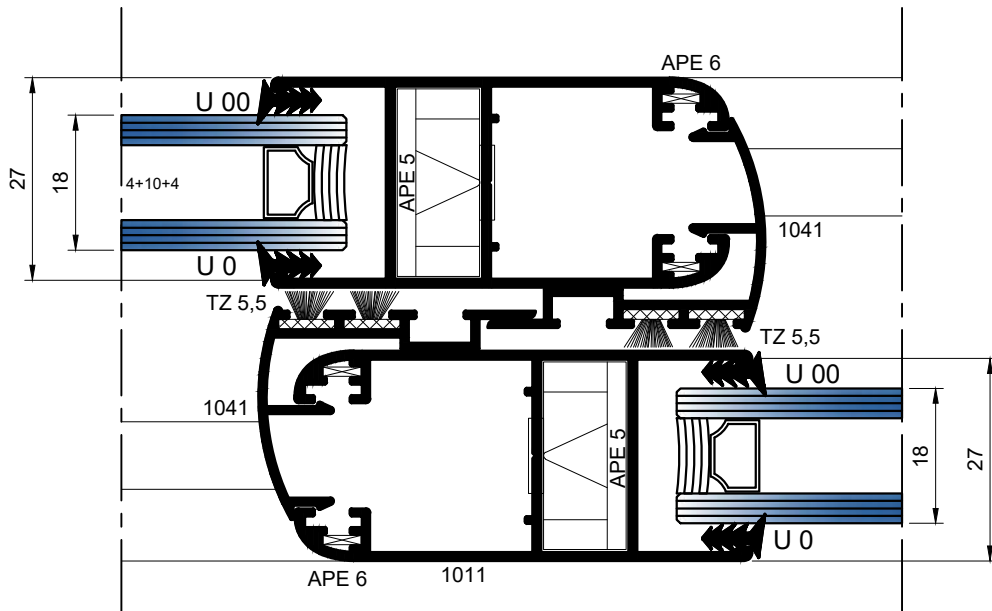
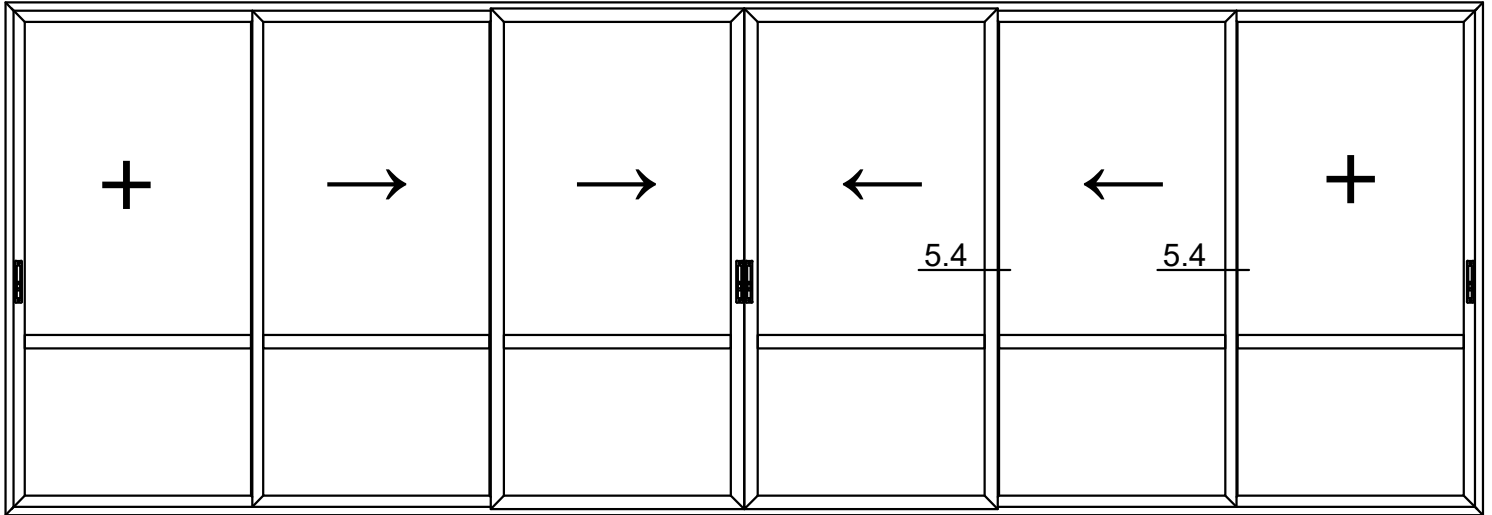

5.4 DETAILS

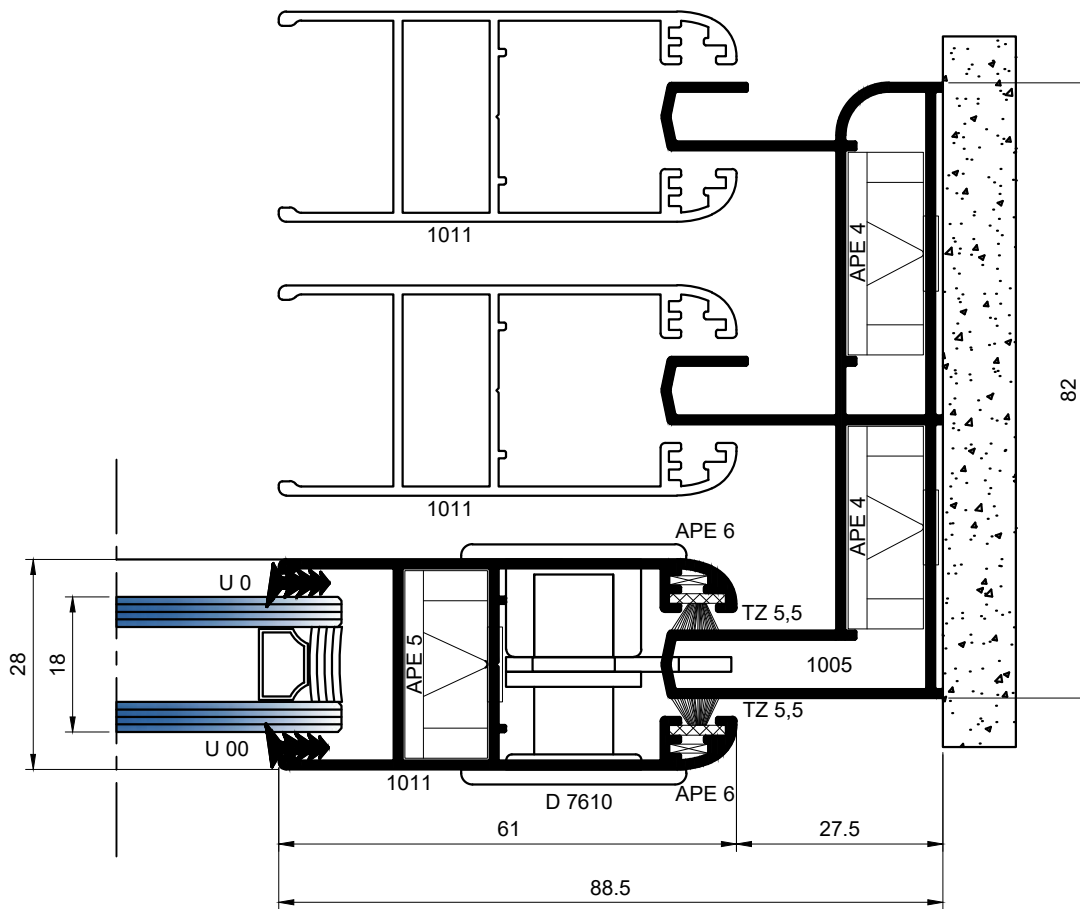
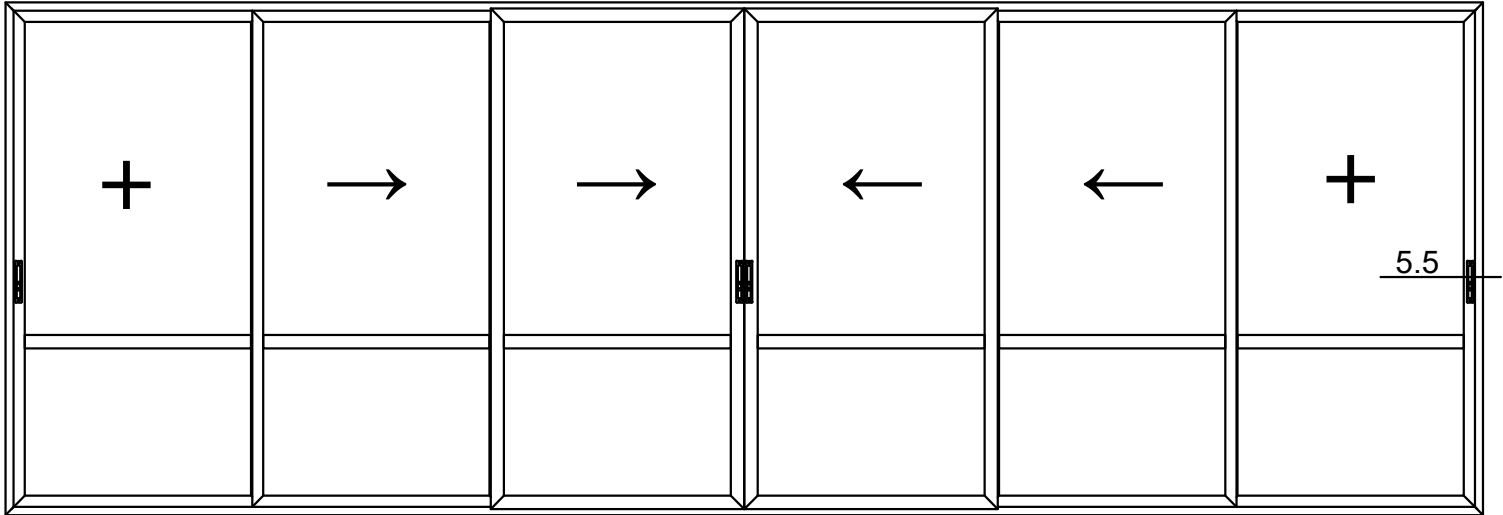

5.5 DETAILS

6

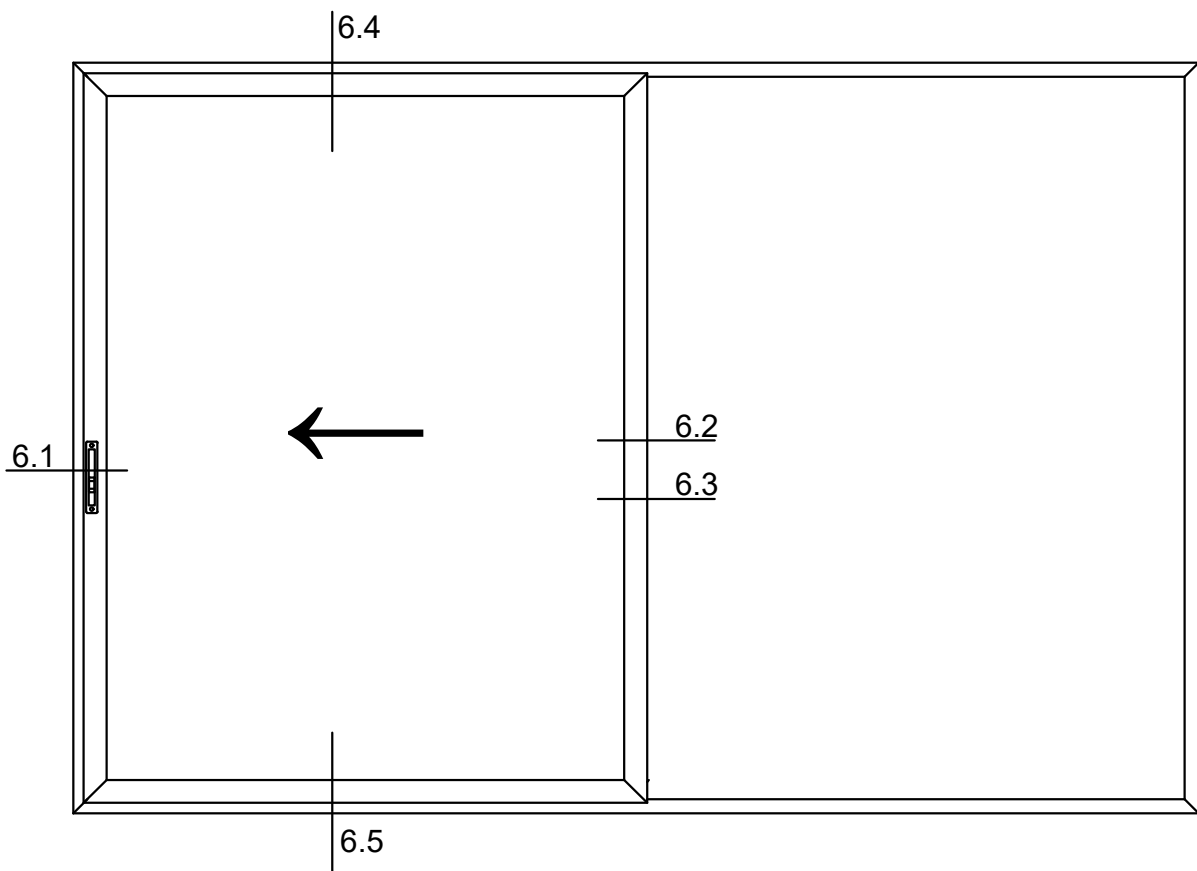

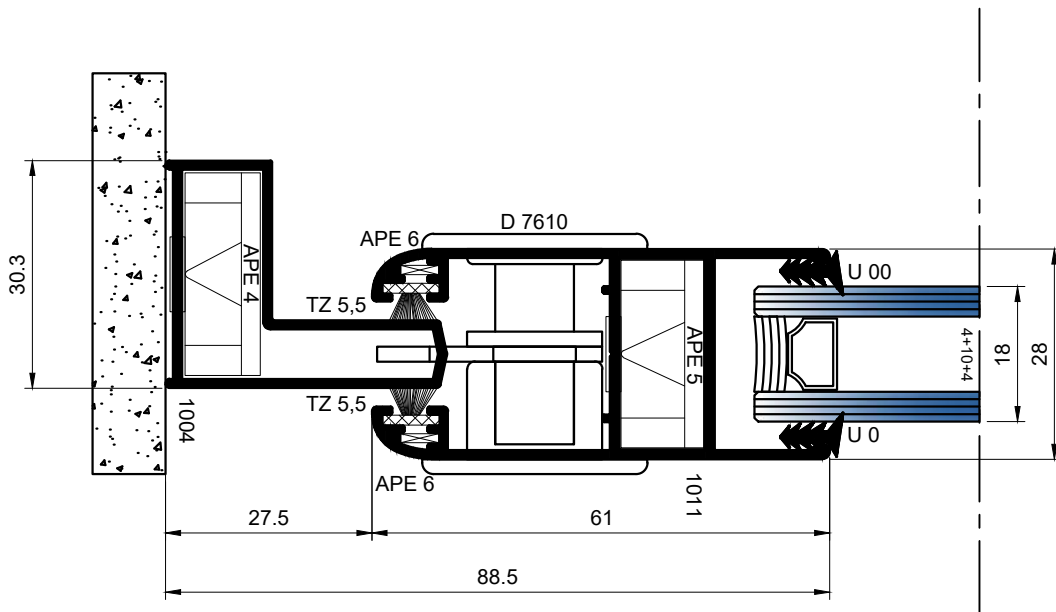
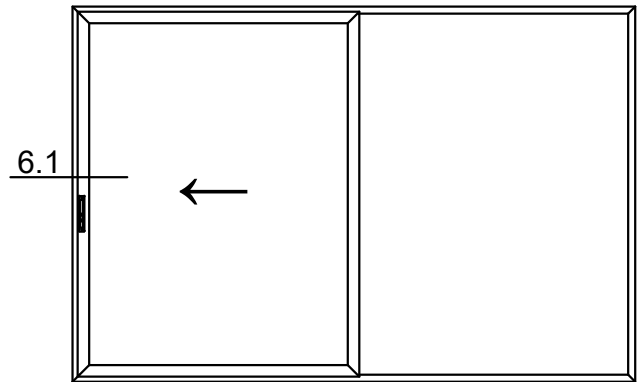

6.1 DETAILS

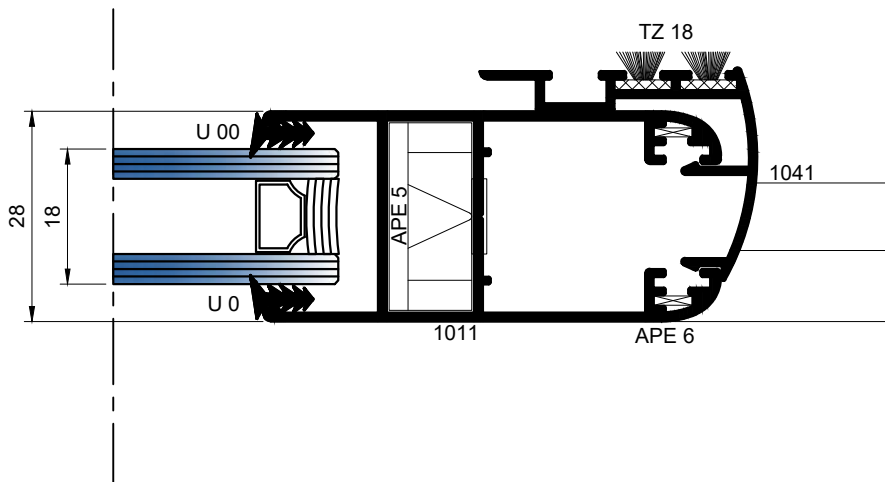
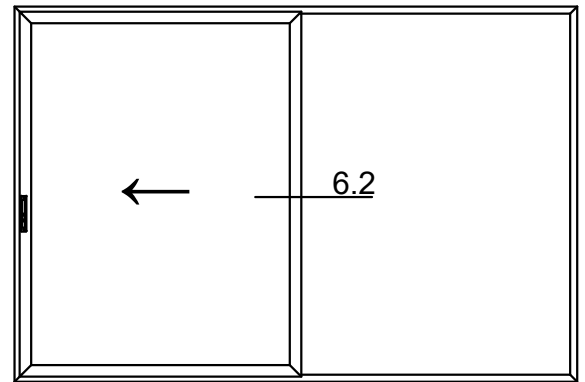

6.2 DETAILS

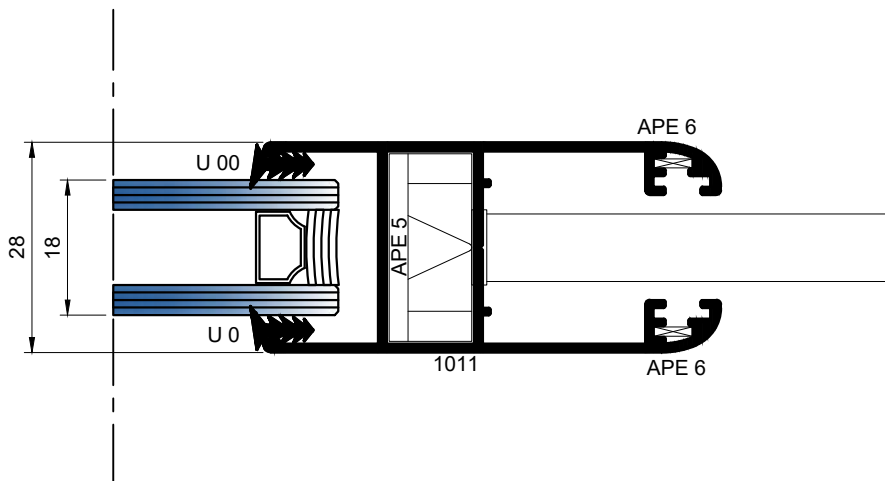
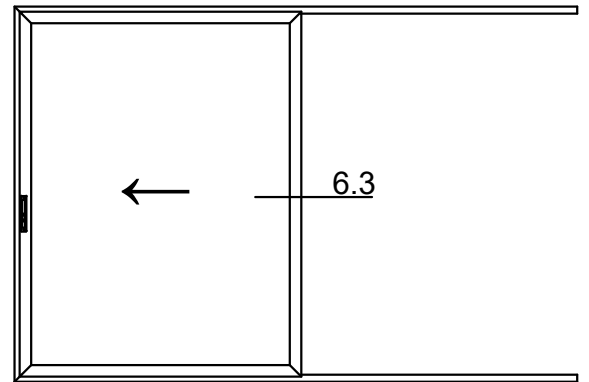

6.3 DETAILS

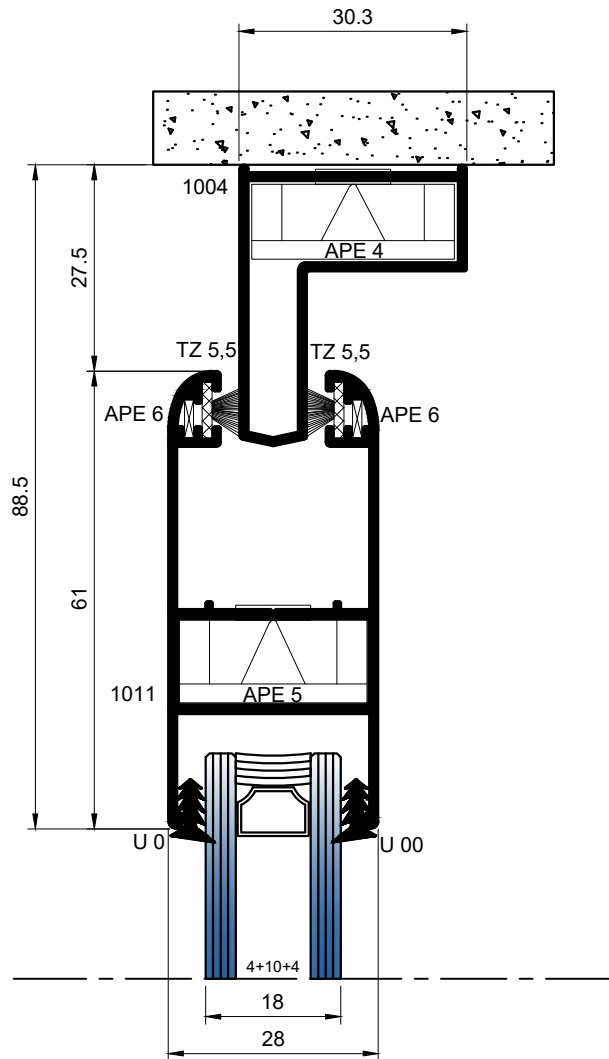
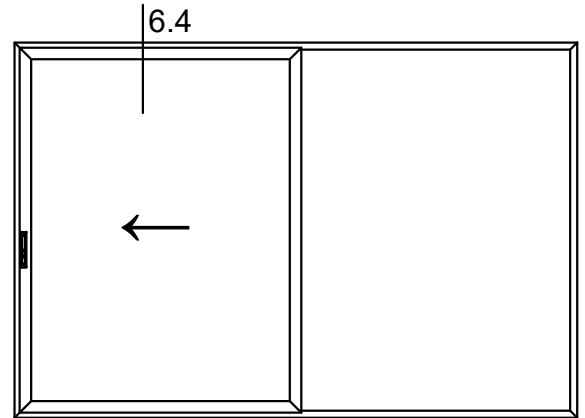

6.4 DETAILS

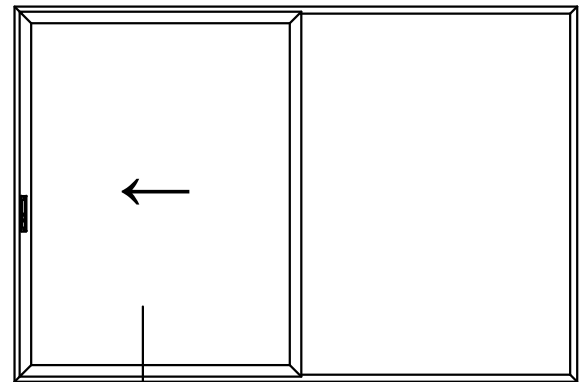

6.5

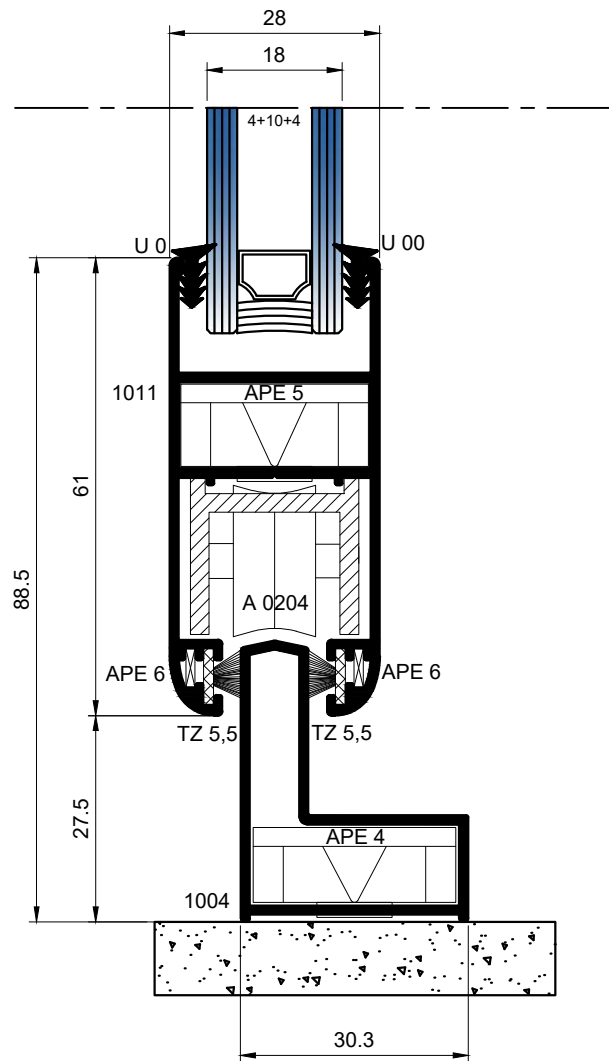

6.4 DETAILS

7

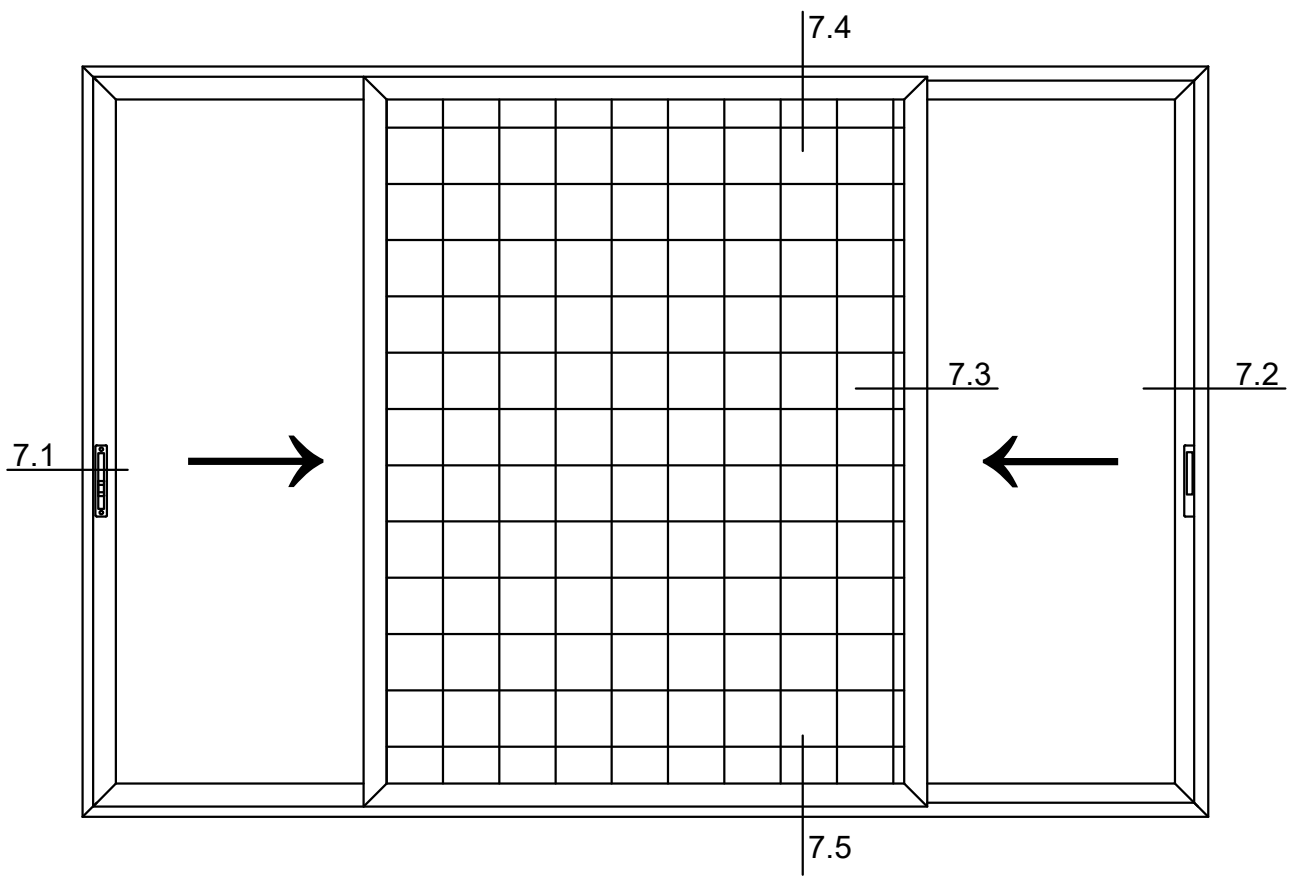

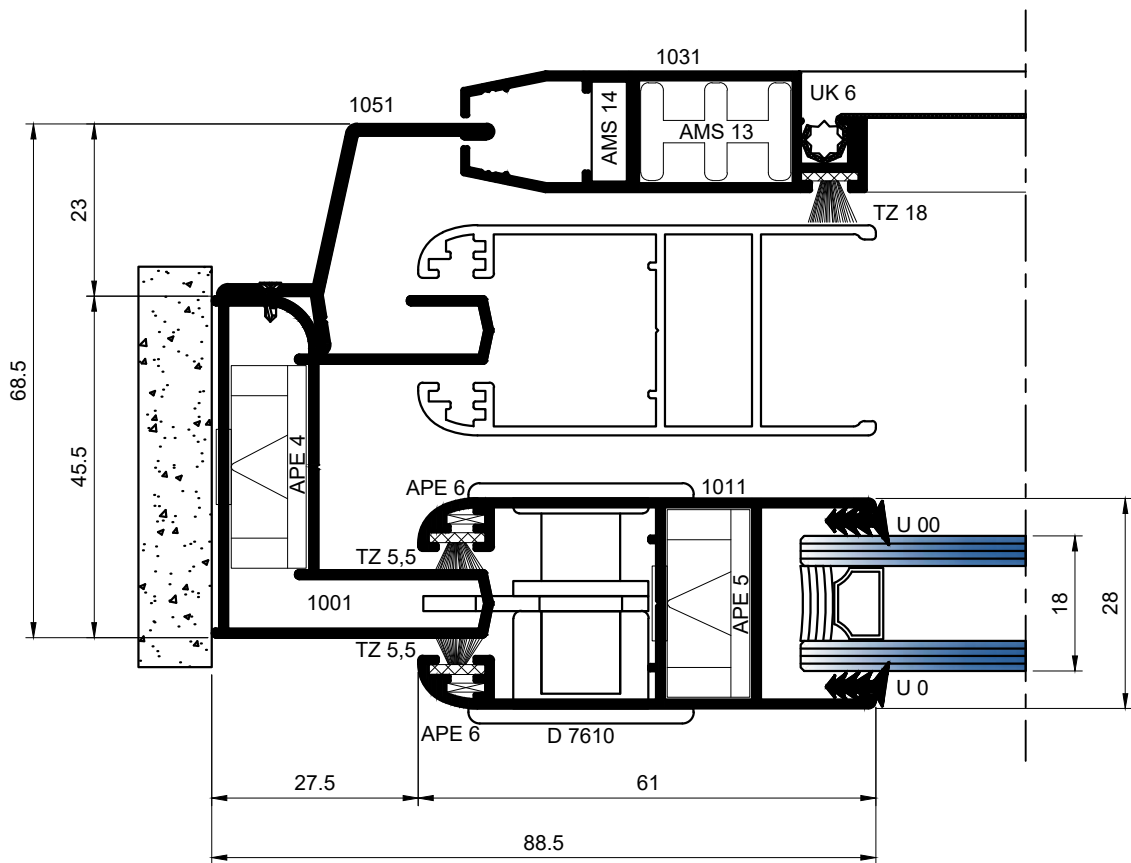
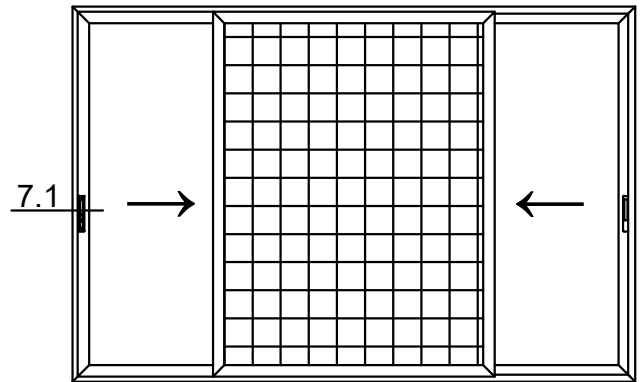

7.1 DETAILS

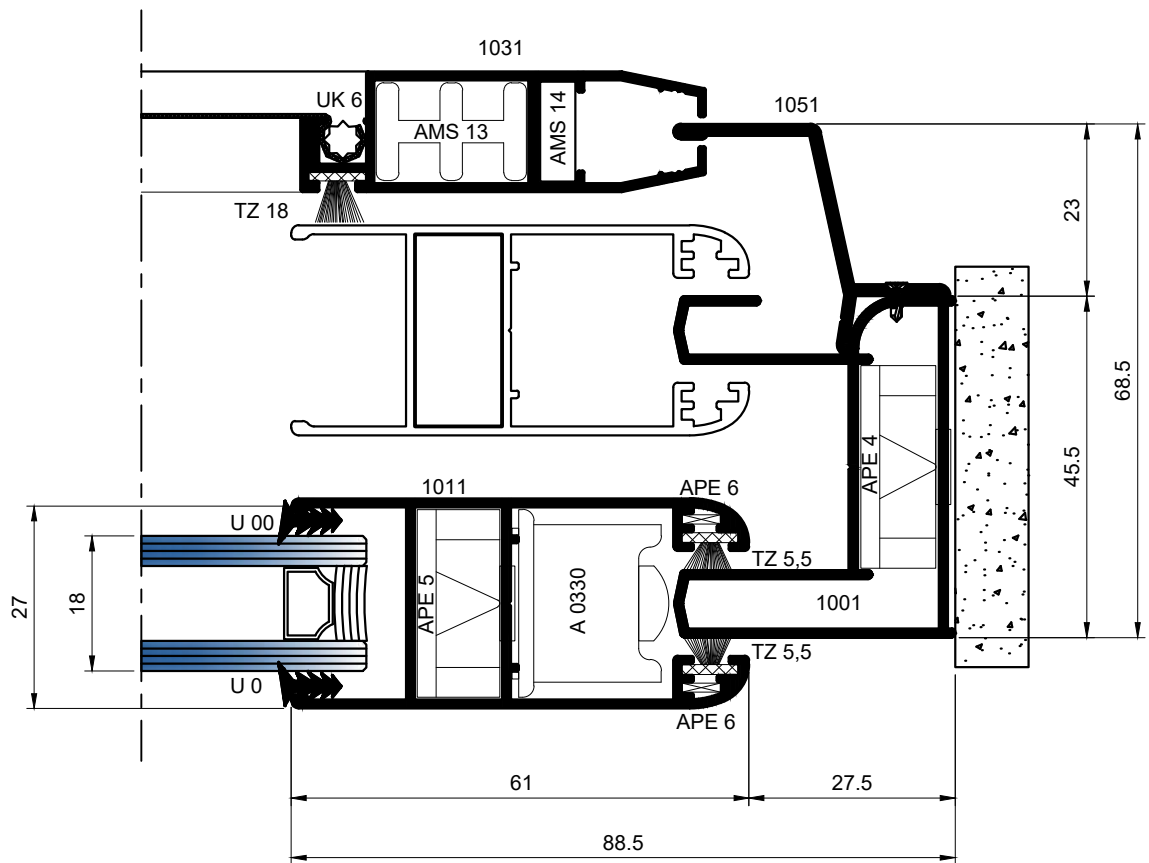
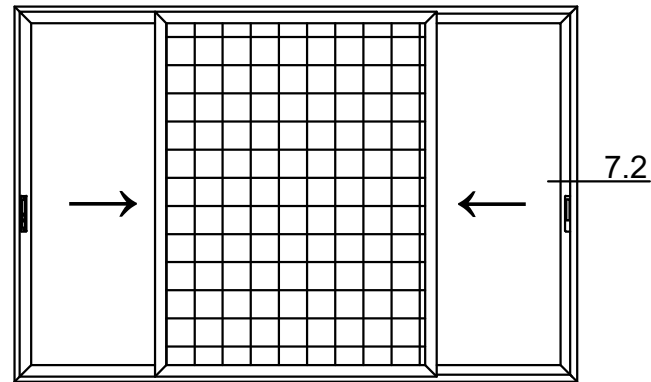

7.2 DETAILS

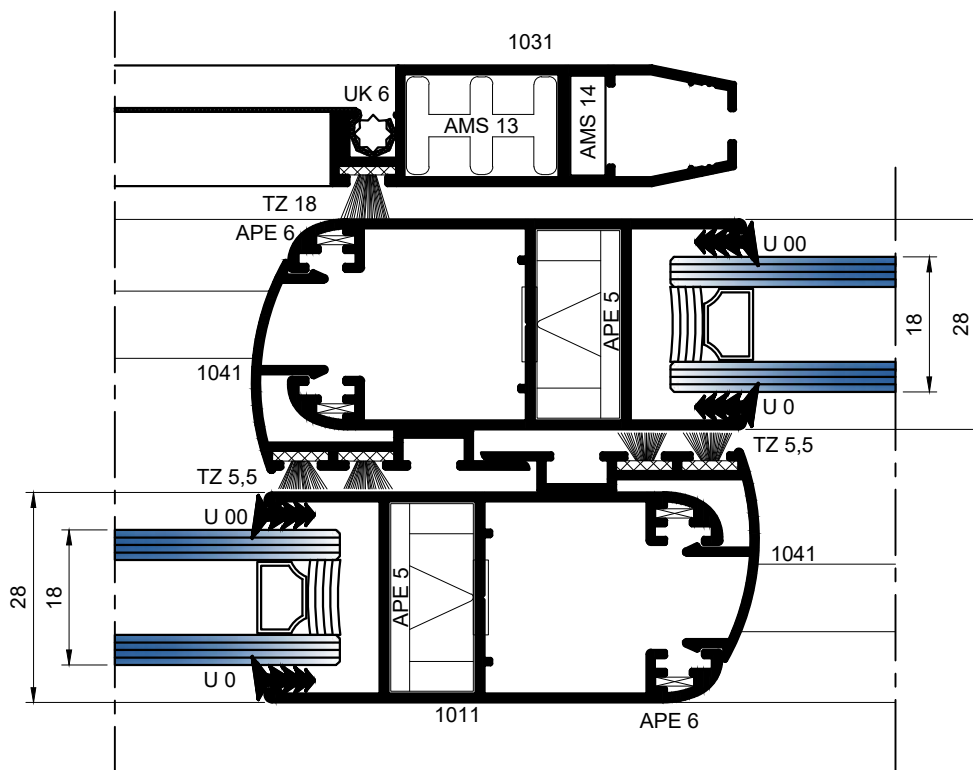
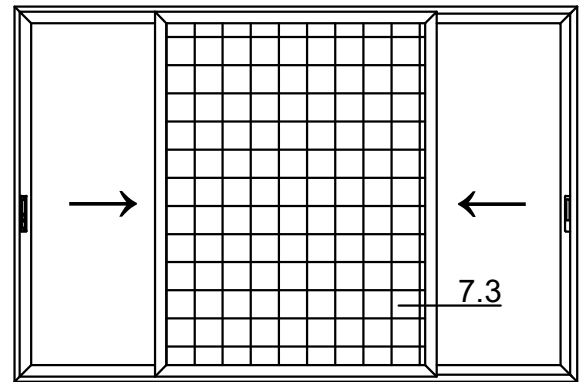

7.3 DETAILS

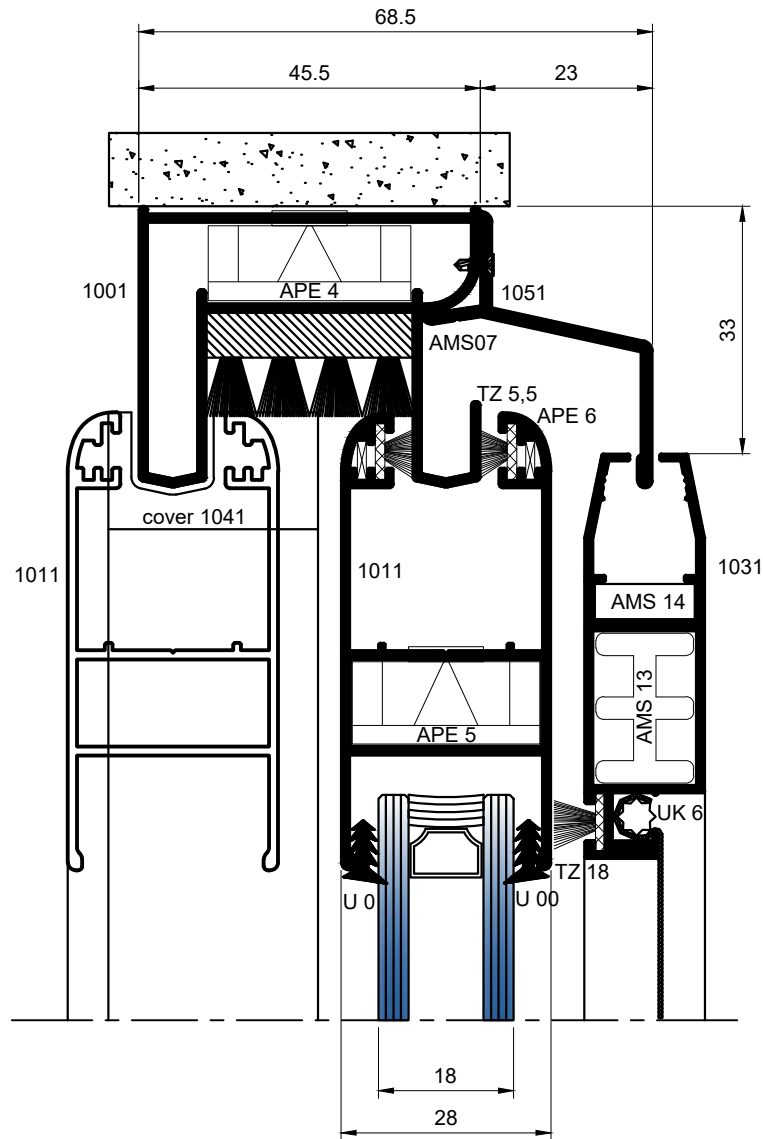
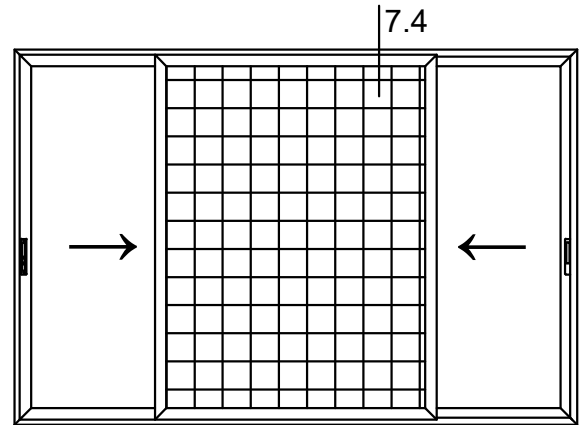

7.4 DETAILS

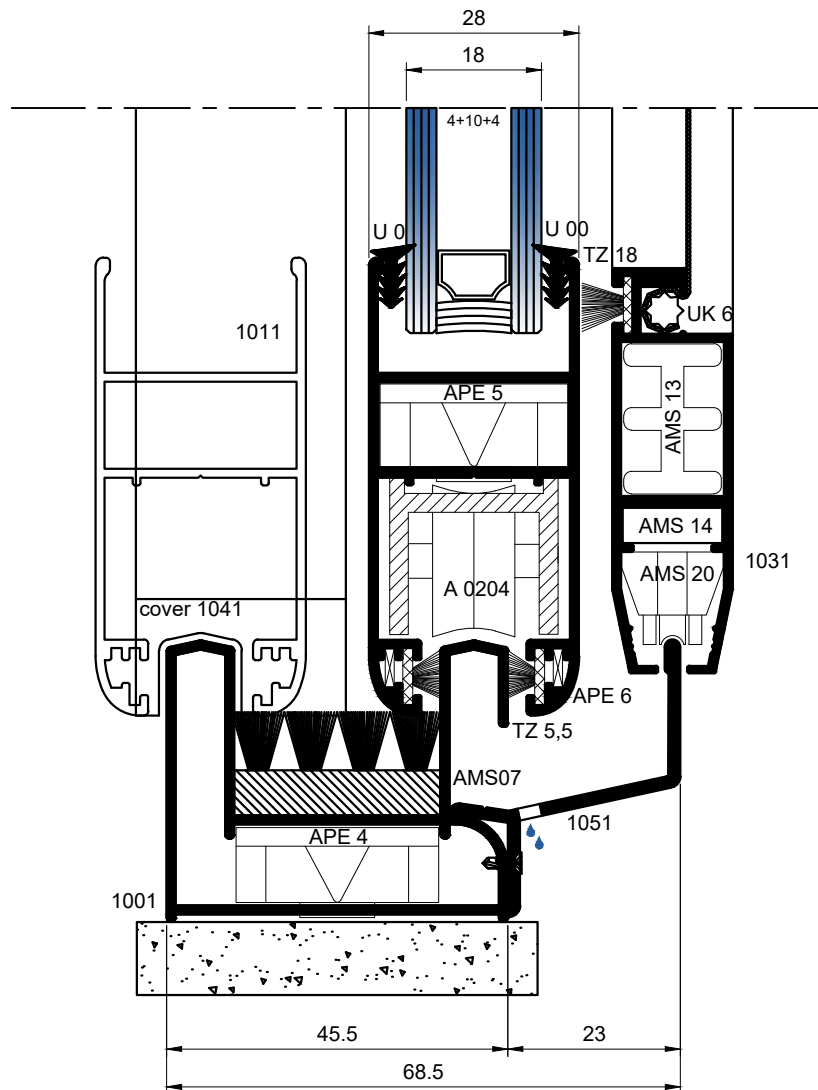
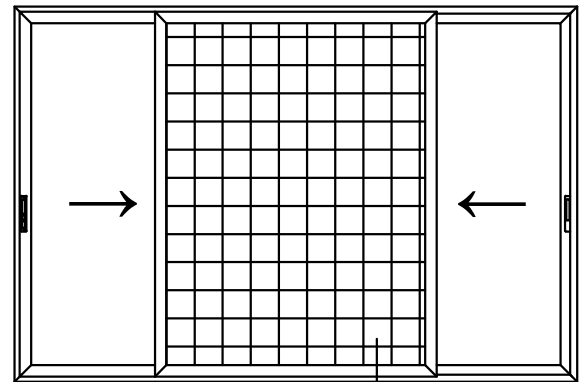

7.5 DETAILS

MINI SLIDING SYSTEM

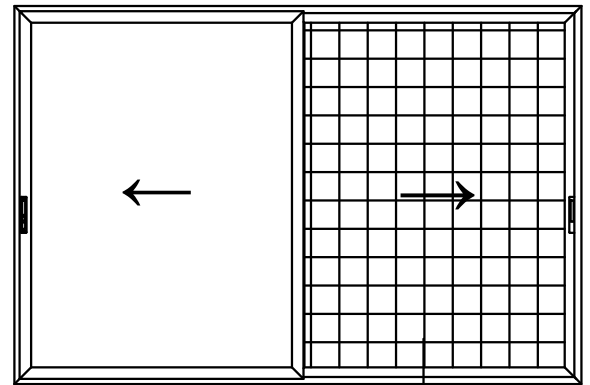

8.1

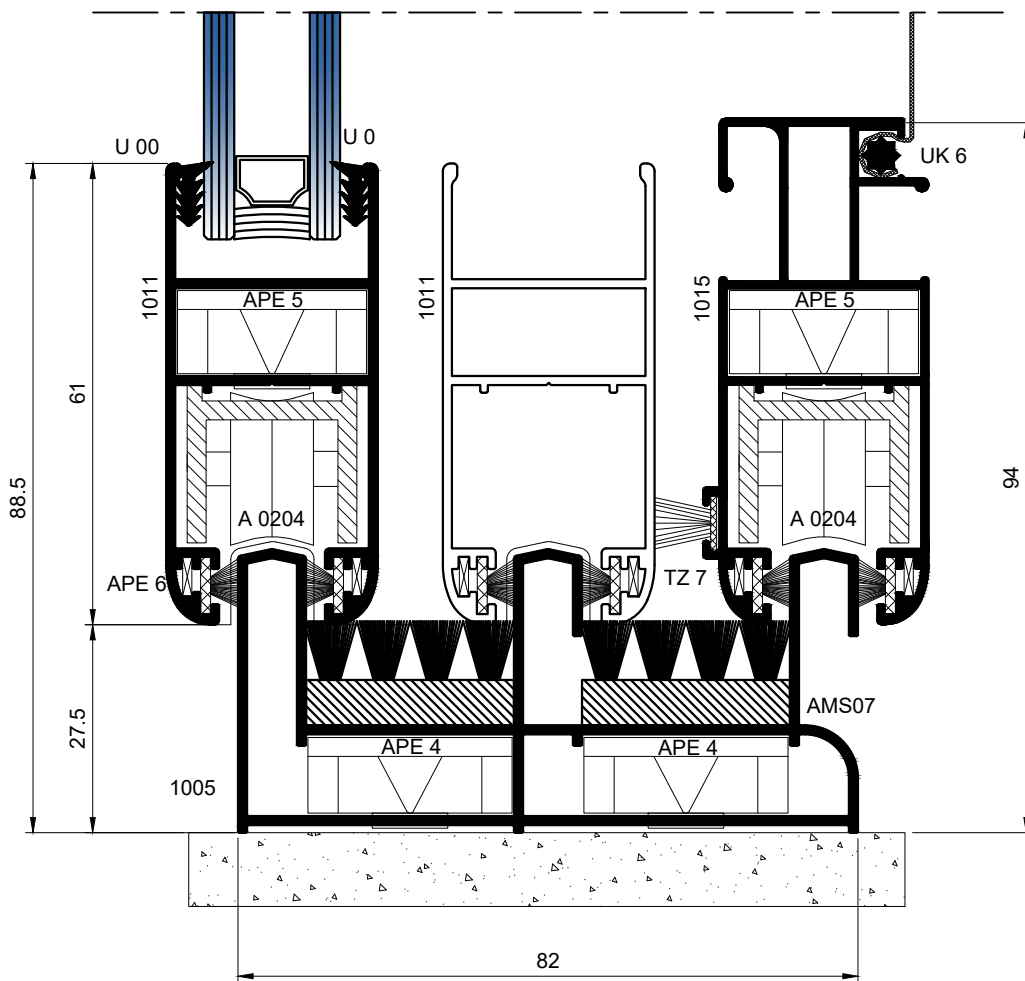

MINI SLIDING SYSTEM

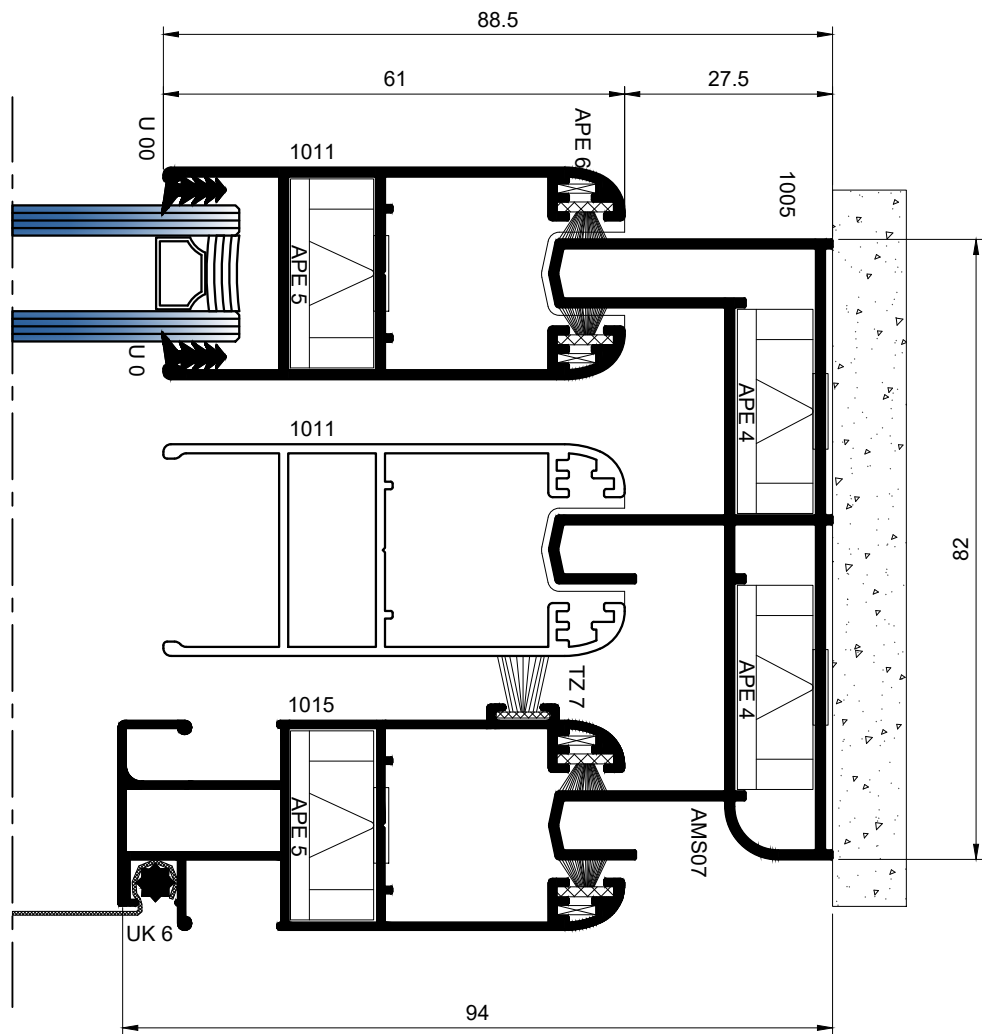
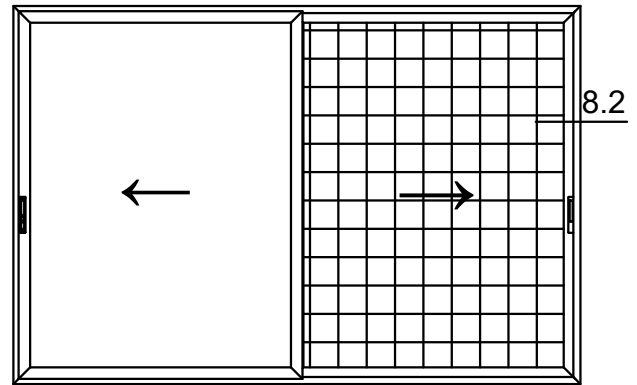

MINI SLIDING SYSTEM

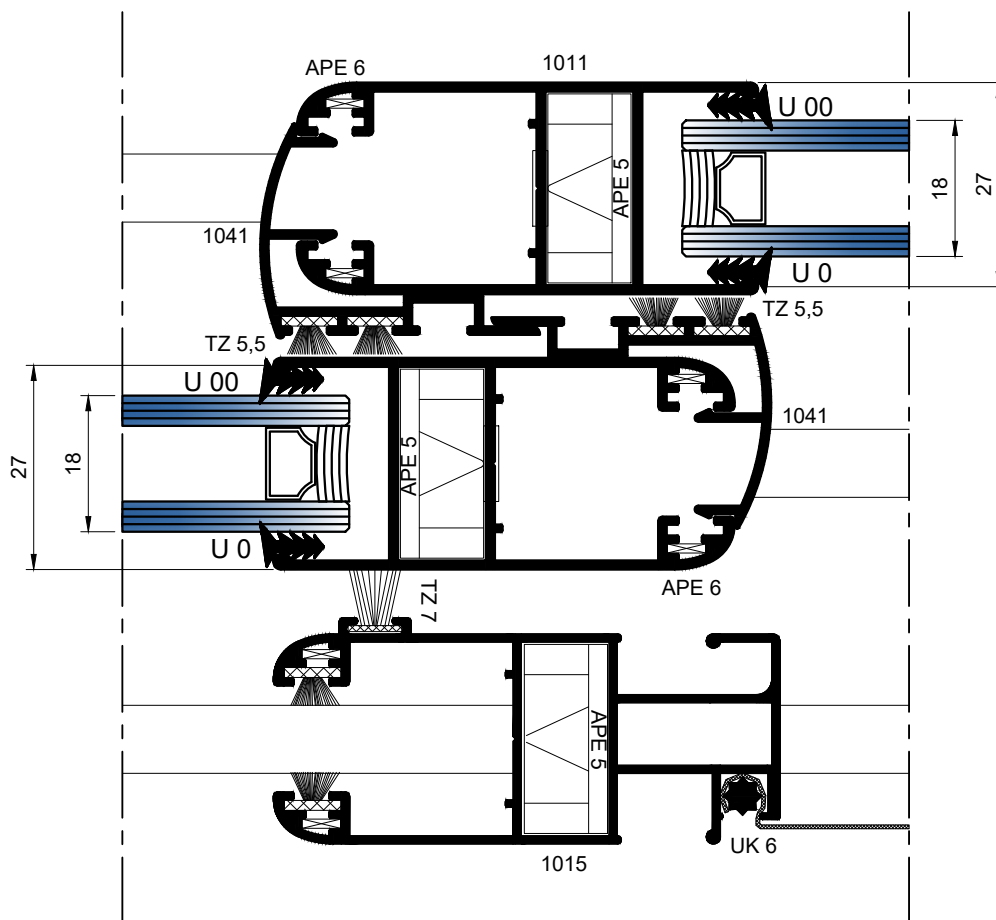
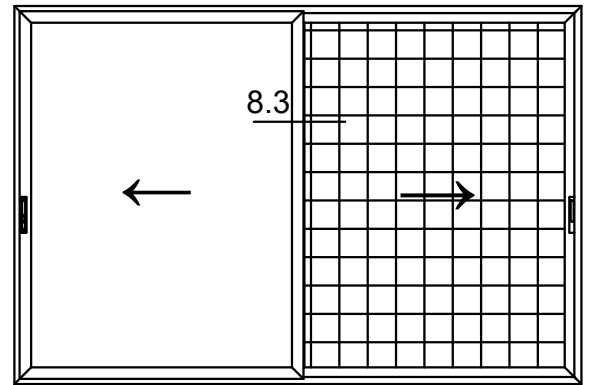

MINI SLIDING SYSTEM

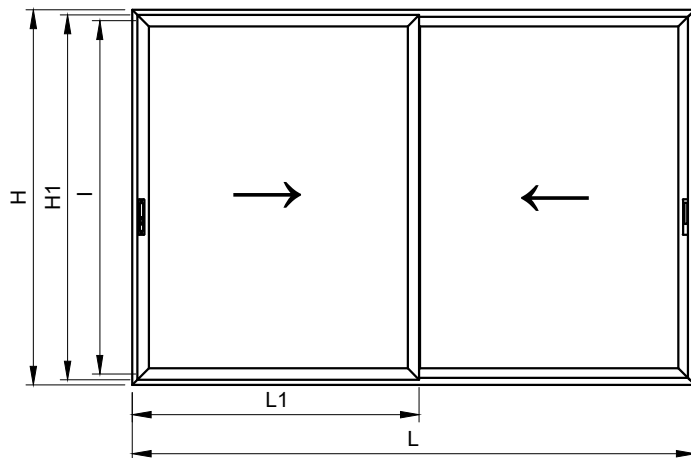

ACCESSOIRES		
CODE	PIECE	DESCRIPTION
APE 4	4	Joint
APE 5	8	Joint
APE 6	16	Joint
A 0330	4	Shock damper
A 0204	4	Rollers
AMS 903	4	Cover for 1041
AMS07	2	Central filling plug
TZ 5,5		Brushes
U 0		EPDM gasket for glass fixing
U 00		EPDM gasket for glass fixing

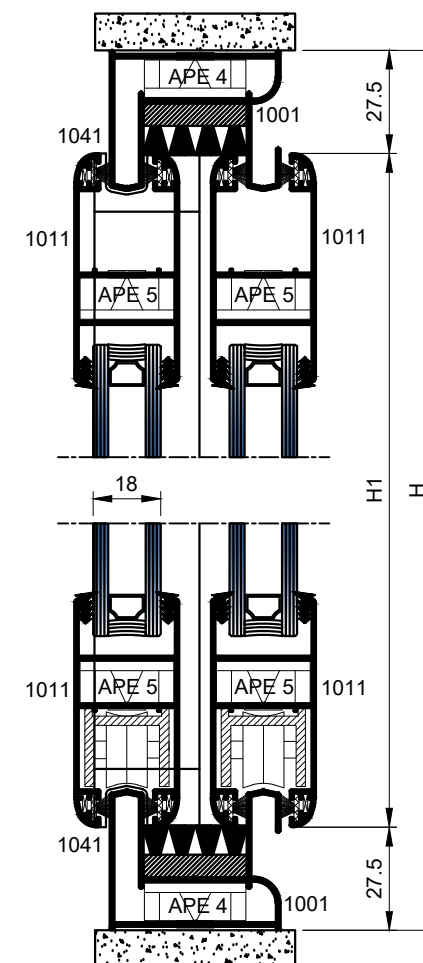
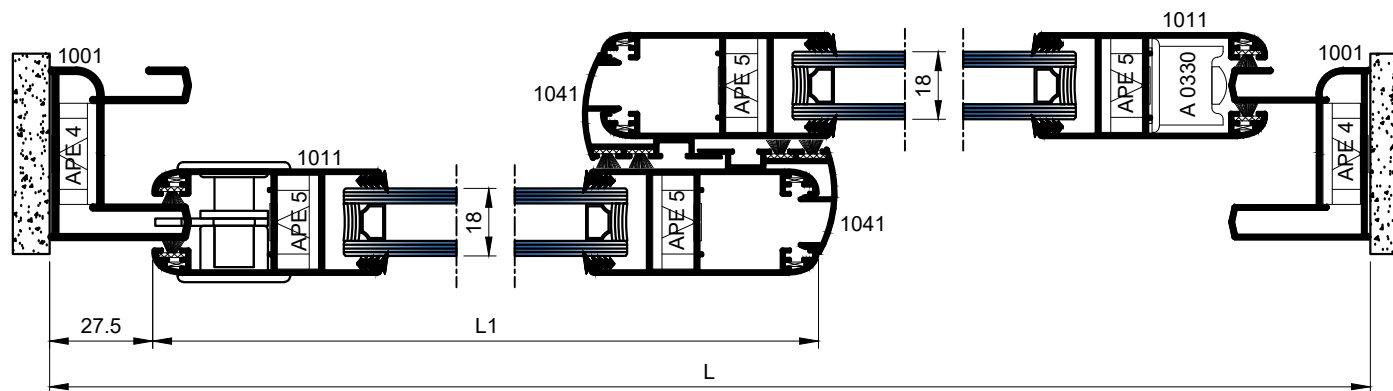

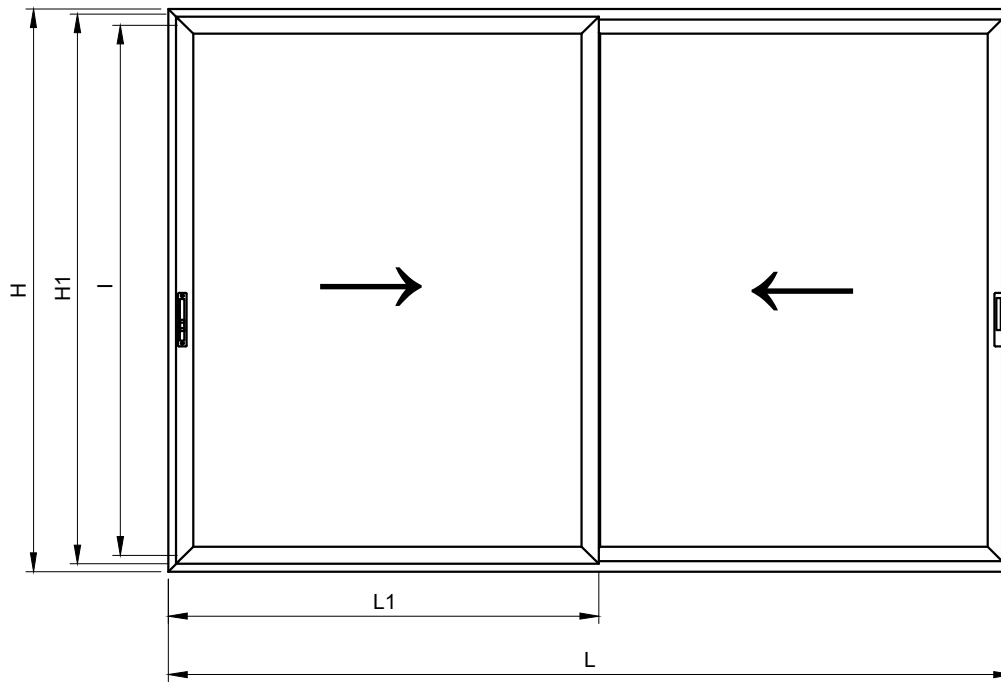

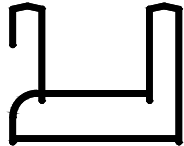
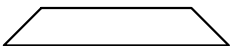
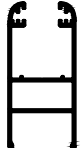
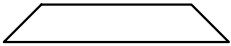
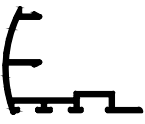
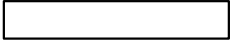
PROFILE CODE	DROWING	DESCRIPTION	CUTING SIZE	ANGLE OF CUTTING	NUMBER
1001		Frame profile	L		2
			H		2
1011		Sash profile	$L1 = L / 2 + 5\text{mm}$		4
			$H1 = H - 54\text{mm}$		4
1041		Addition for double wing profile	$I = H1 - 35\text{mm}$		2

MINI SLIDING SYSTEM

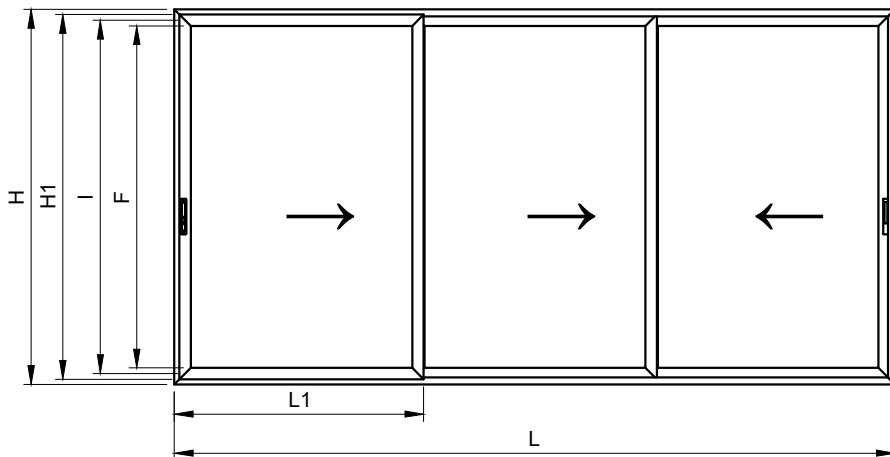

ACCESSOIRES		
CODE	PIECE	DESCRIPTION
APE 4	8	Joint
APE 5	12	Joint
APE 6	24	Joint
A 0330	4	Shock damper
A 0204	6	Rollers
AMS 903	8	Cover for 1041
AMS07	4	Central filling plug
TZ 5,5		Brushes
U 0		EPDM gasket for glass fixing
U 00		EPDM gasket for glass fixing

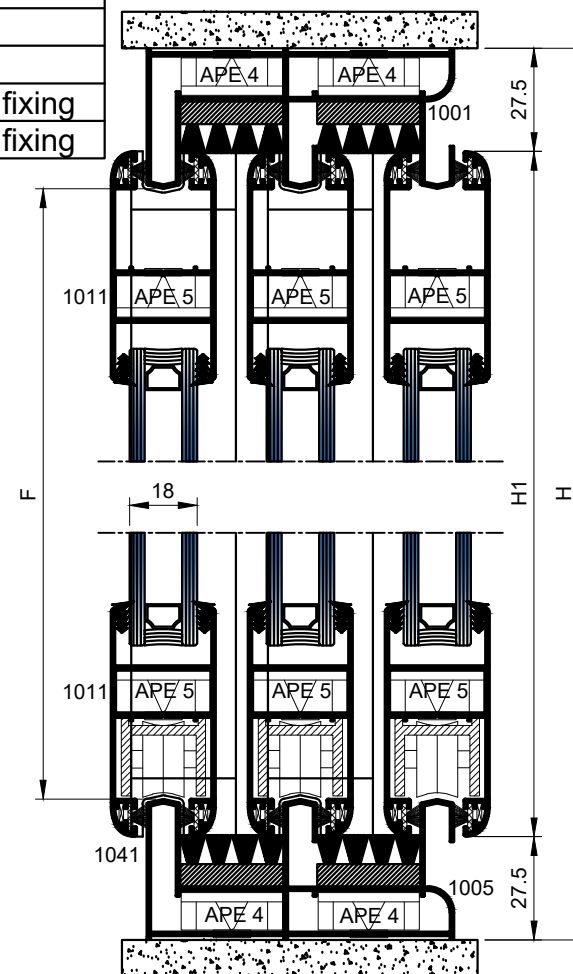
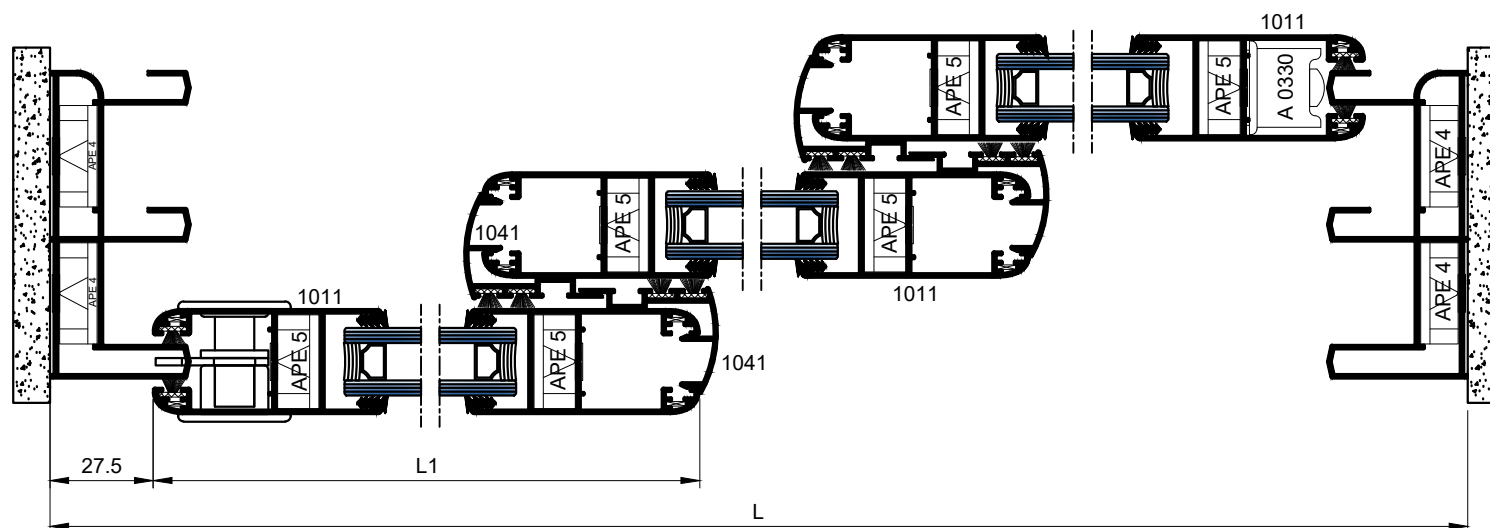

MINI SLIDING SYSTEM

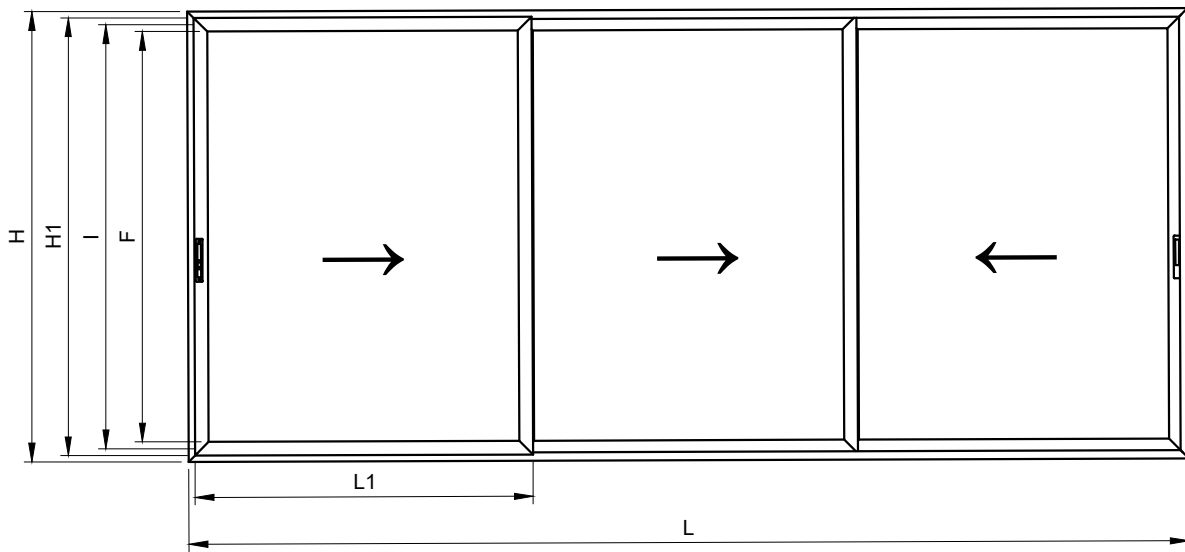

PROFILE CODE	DROWING	DESCRIPTION	CUTING SIZE	ANGLE OF CUTTING	NUMBER
1001		Frame profile	L		2
			H		2
1011		Sash profile	$L1 = L/3 + 22\text{mm}$		6
			$H1 = H - 54\text{mm}$		6
1041		Addition for double wing profile	$I = H1 - 35\text{mm}$		4
1071		Adaptor profile	$F = H - 74\text{mm}$		1
2042		Glass holder profile	L1-121mm		6
			H1-123mm		6

MINI SLIDING SYSTEM

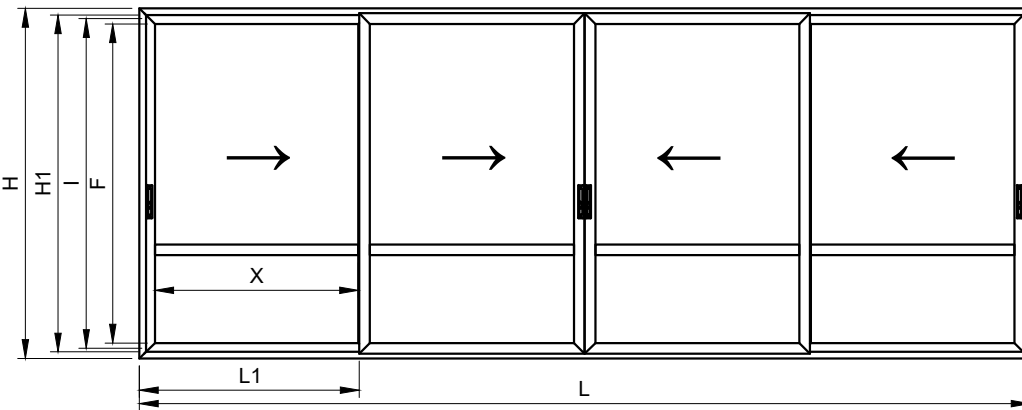



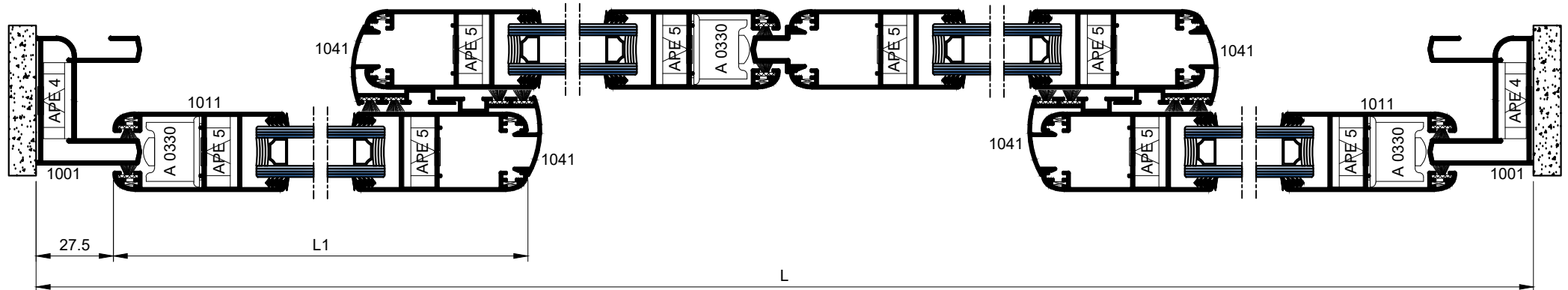
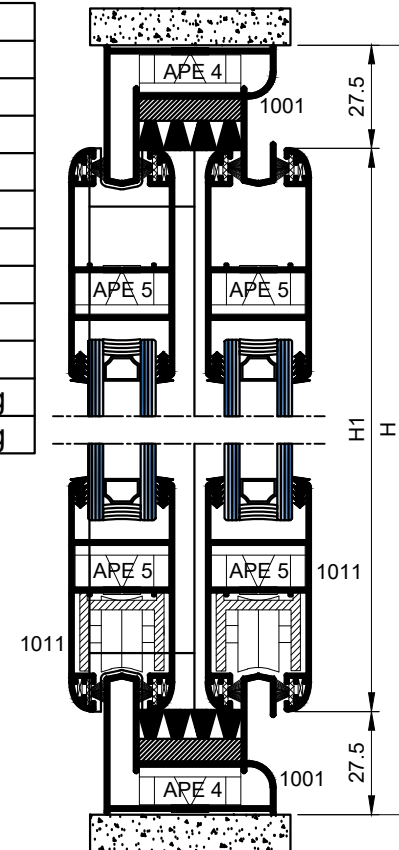

ACCESSOIRES		
CODE	PIECE	DESCRIPTION
APE 4	4	Joint
APE 5	16	Joint
APE 6	32	Joint
A 0330	6	Shock damper
A 0204	8	Rollers
AMS 903	8	Cover for 1041
AMS07	4	Central filling plug
TZ 5,5		Brushes
U 0		EPDM gasket for glass fixing
U 00		EPDM gasket for glass fixing

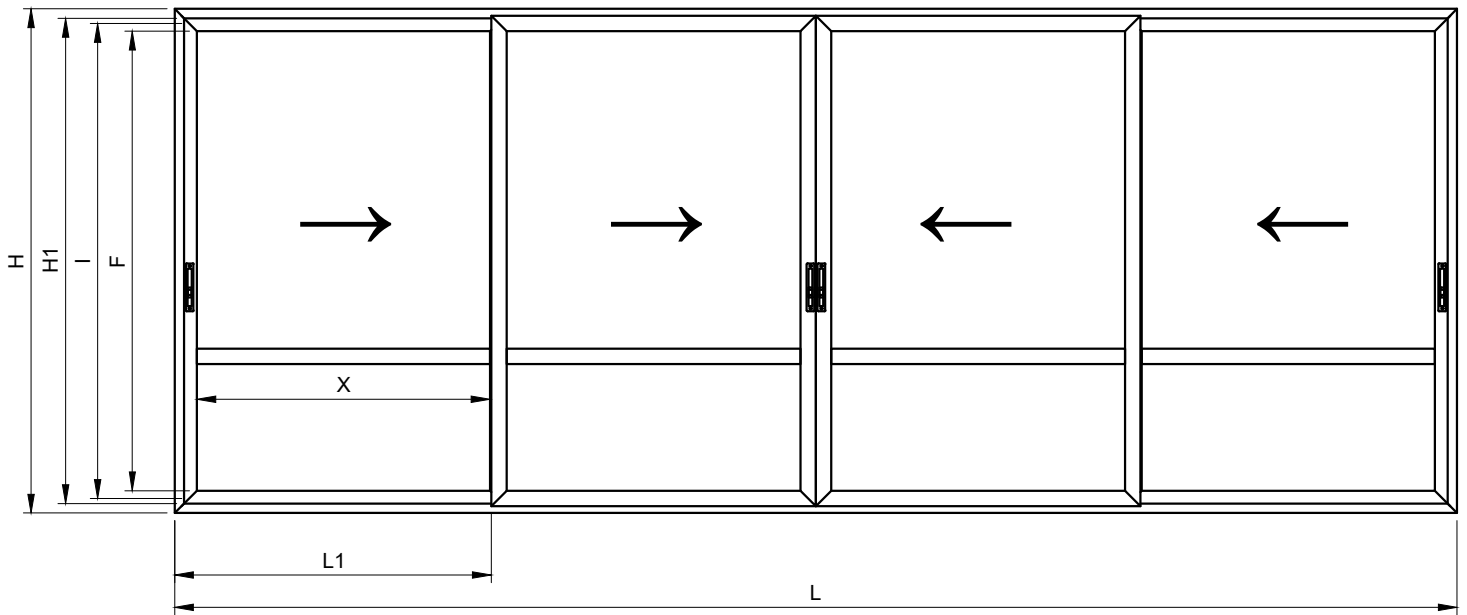

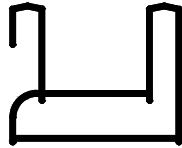
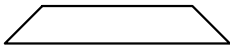
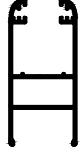
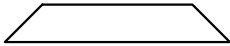
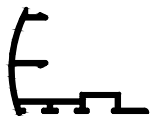
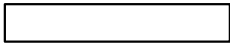
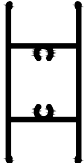
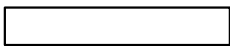
MINI SLIDING SYSTEM

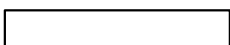

PROFILE CODE	DROWING	DESCRIPTION	CUTING SIZE	ANGLE OF CUTTING	NUMBER
1001		Frame profile	L		2
			H		2
1011		Sash profile	$L1 = L/4 + 16\text{mm}$		8
			$H1 = H - 54\text{mm}$		8
1041		Addition for double wing profile	$I = H1 - 35\text{mm}$		4
1024		Mullion profile	$X = H1 - 122\text{mm}$		4
1071		Adaptor profile	$F = H - 74\text{mm}$		1
2042		Glass holder profile	L1-121mm		8
			H1-123mm		8

MINI SLIDING SYSTEM

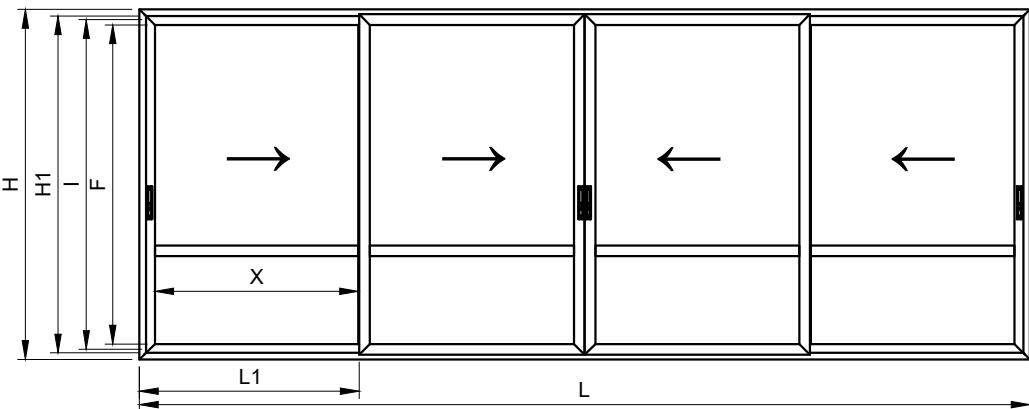

ACCESSOIRES		
CODE	PIECE	DESCRIPTION
APE 4	4	Joint
APE 5	16	Joint
APE 6	32	Joint
A 0330	6	Shock damper
A 0204	8	Rollers
AMS 903	8	Cover for 1041
AMS 30	8	Cover for 2022
AMS07	4	Central filling plug
TZ 5,5		Brushes
U 0		EPDM gasket for glass fixing
U 00		EPDM gasket for glass fixing

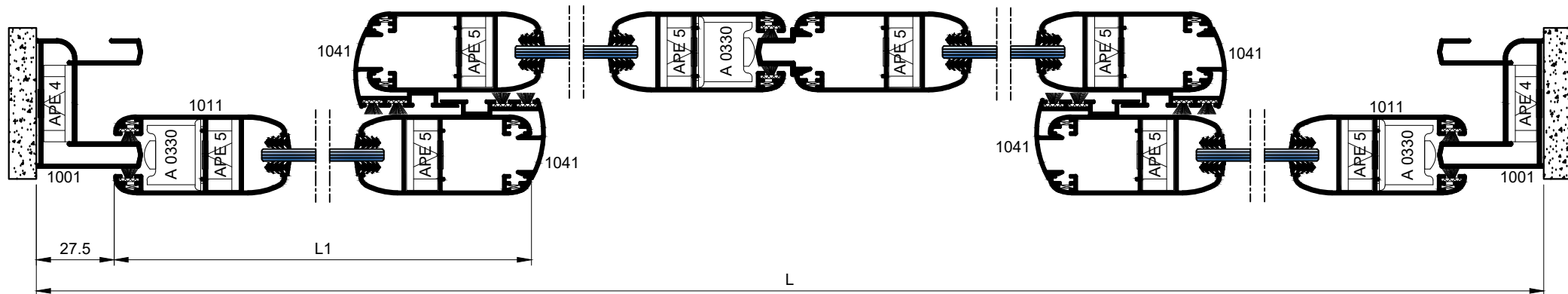
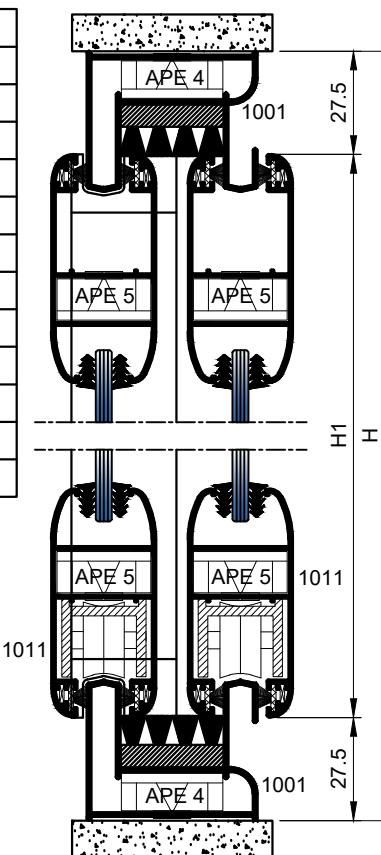

MINI SLIDING SYSTEM

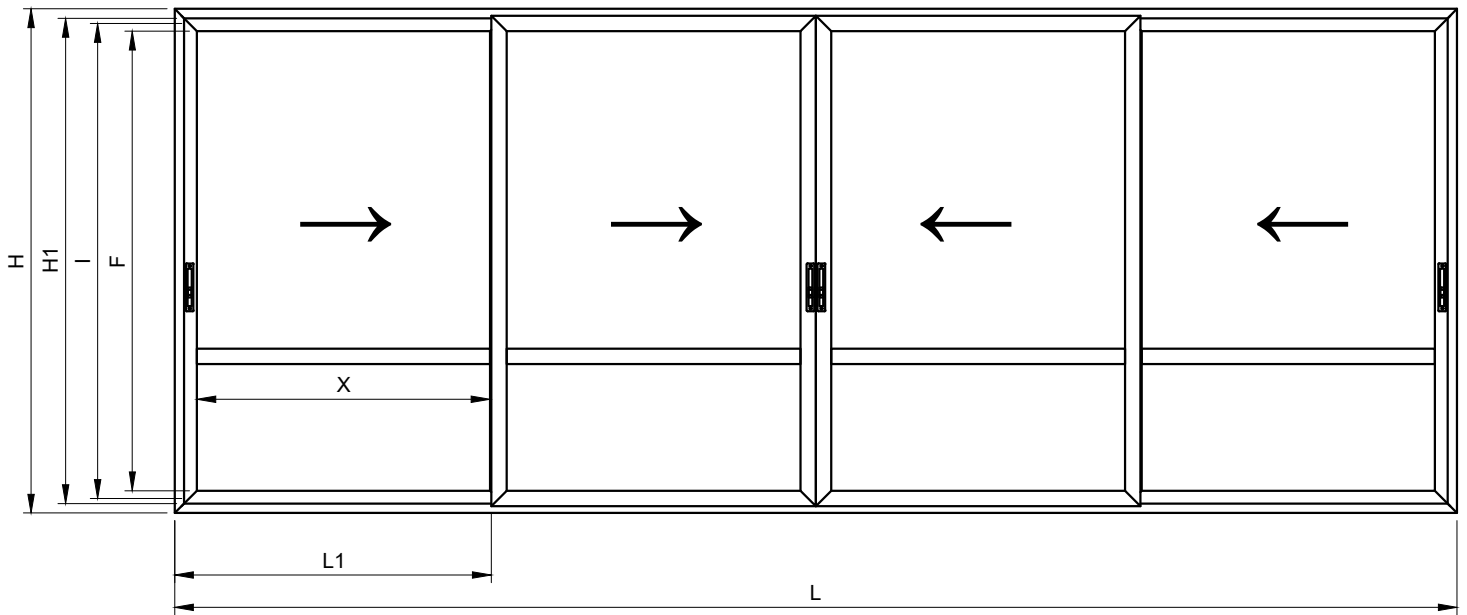

PROFILE CODE	DROWING	DESCRIPTION	CUTING SIZE	ANGLE OF CUTTING	NUMBER
1001		Frame profile	L		2
			H		2
1011		Sash profile	$L1 = L/4 + 16\text{mm}$		8
			$H1 = H - 54\text{mm}$		8
1041		Addition for double wing profile	$I = H1 - 35\text{mm}$		4
2022		2022 Sash profile	$X = H1 - 125.5\text{mm}$		4
1071		Adaptor profile	$F = H - 74\text{mm}$		1

MINI SLIDING SYSTEM

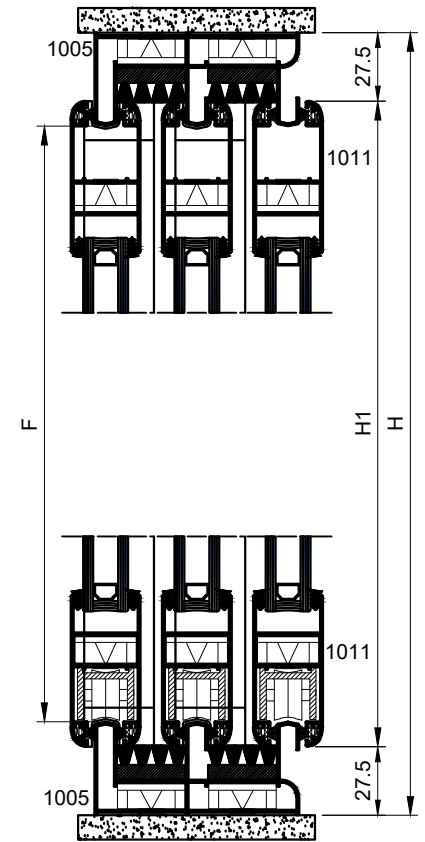
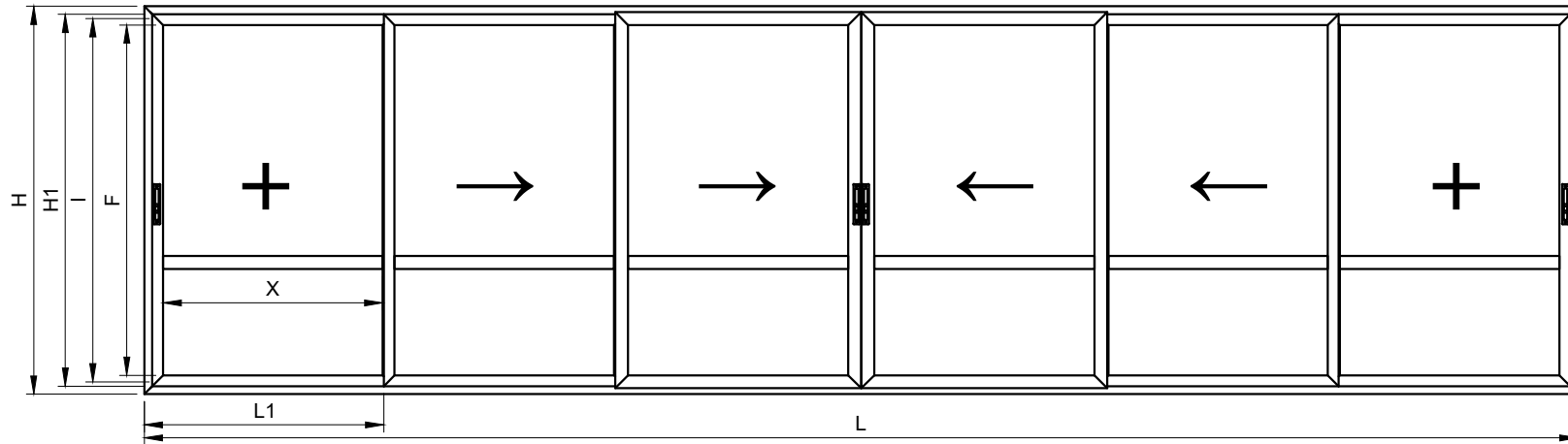



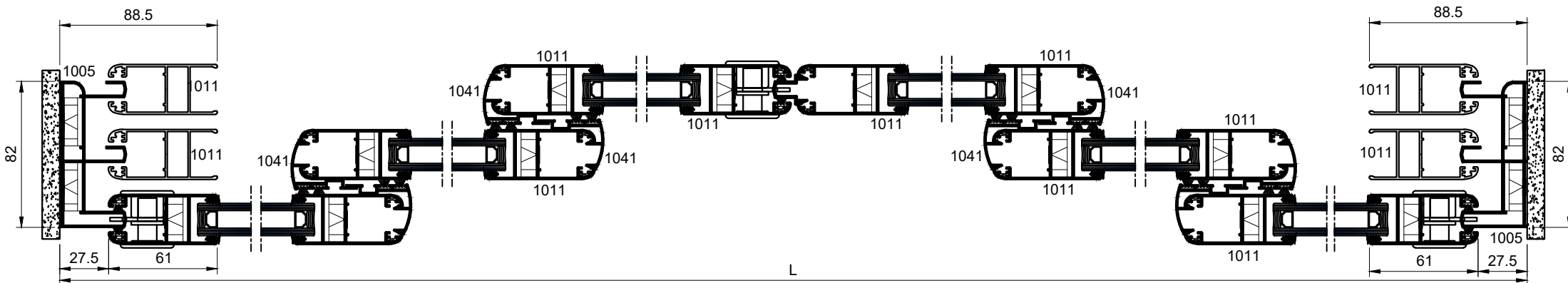

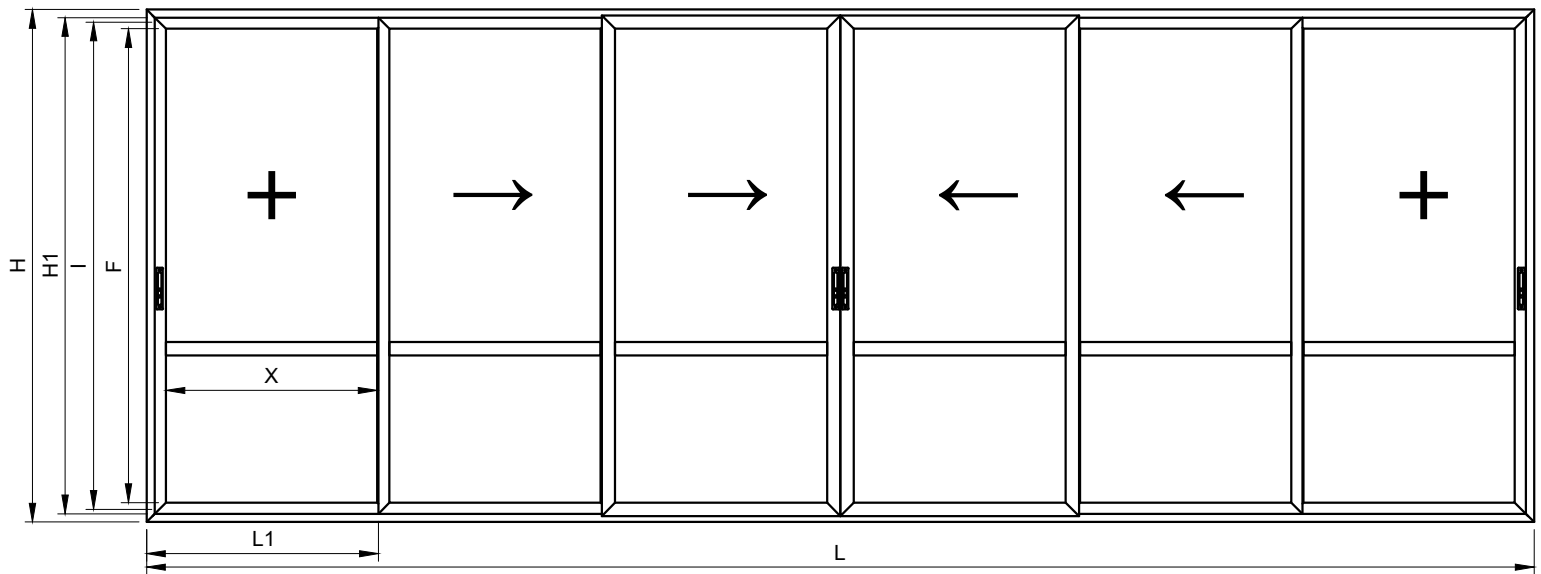

ACCESSOIRES		
CODE	PIECE	DESCRIPTION
APE 4	8	Joint
APE 5	24	Joint
APE 6	48	Joint
A 0330	6	Shock damper
A 0204	12	Rollers
AMS 903	16	Cover for 1041
AMS07	6	Central fillung plug
TZ 5,5		Brushes
U 0		EPDM gasket for glass fixing
U 00		EPDM gasket for glass fixing

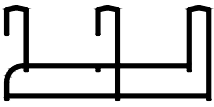

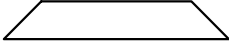
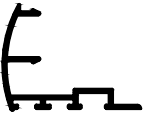
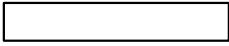
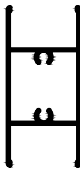
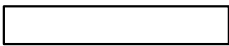
MINI SLIDING SYSTEM

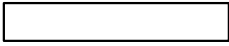

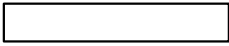
PROFILE CODE	DROWING	DESCRIPTION	CUTING SIZE	ANGLE OF CUTTING	NUMBER
1001		Frame profile	L		2
			H		2
1011		Sash profile	$L1 = L/6 + 31\text{mm}$		12
			$H1 = H - 54\text{mm}$		12
1041		Addition for double wing profile	$I = H1 - 35\text{mm}$		8
1024		Mullion profile	$X = H1 - 122$		6
1071		Adaptor profile	$F = H - 74\text{mm}$		1
2042		Glass holder profile	L1-121mm		8
			H1-123mm		8

MINI SLIDING SYSTEM

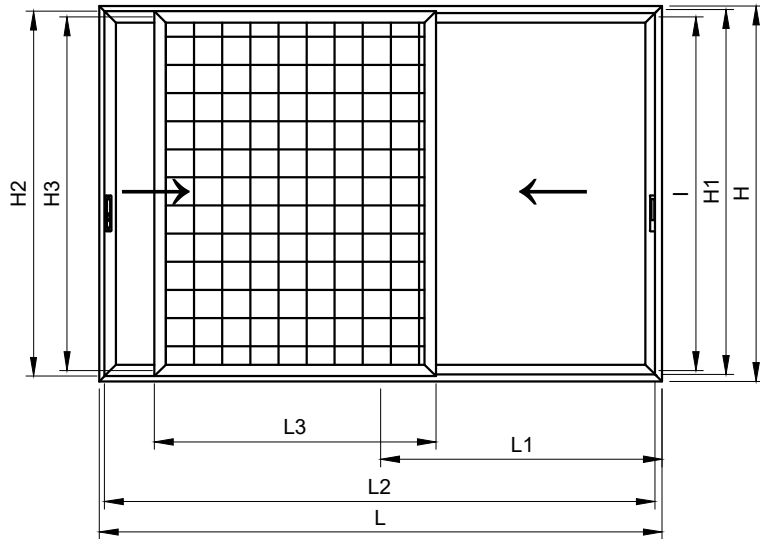



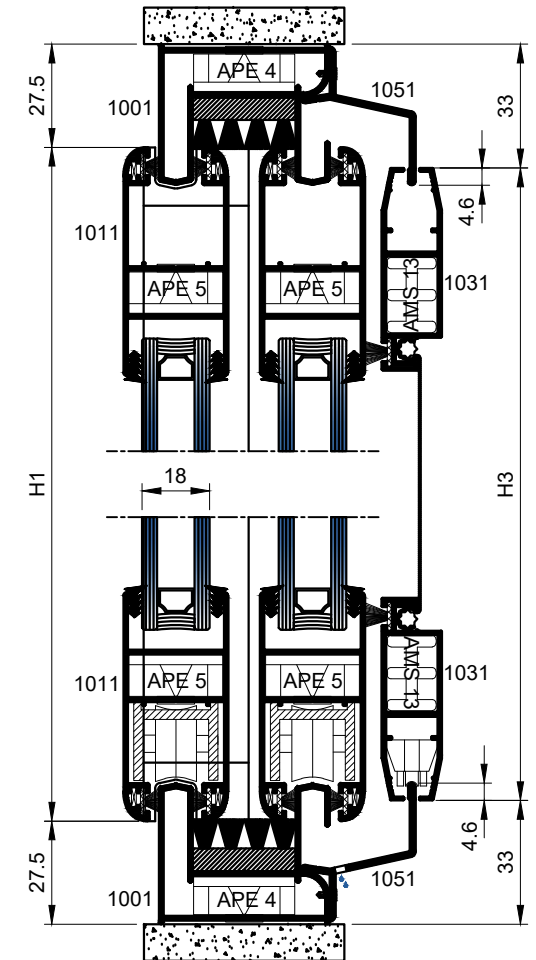
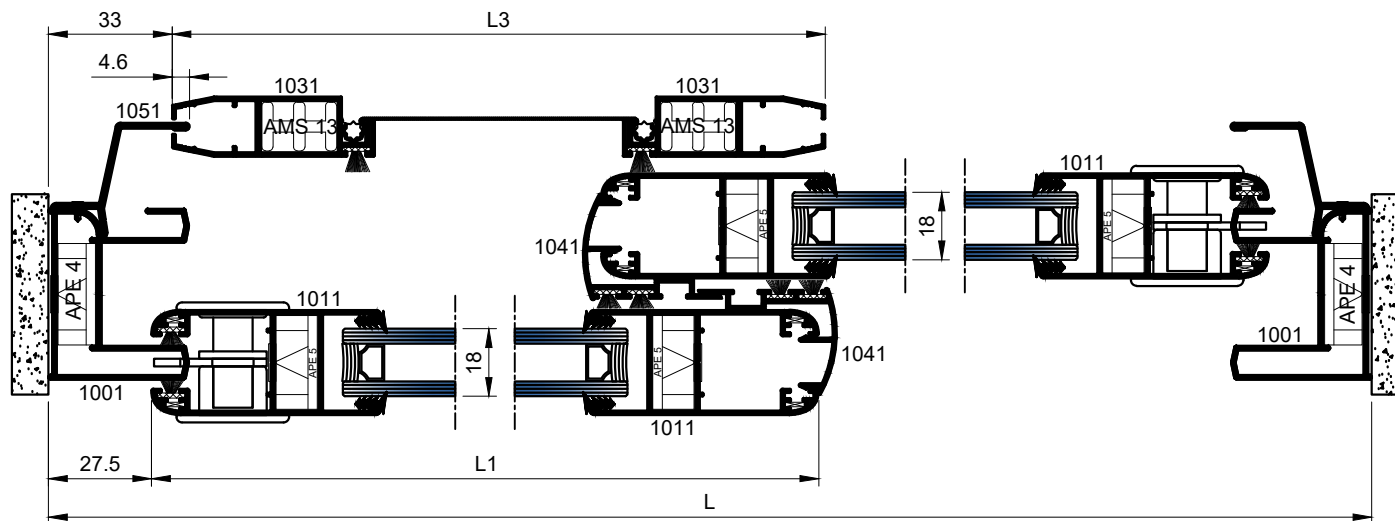

ACCESSOIRES		
CODE	PIECE	DESCRIPTION
APE 4	4	Joint
APE 5	8	Joint
APE 6	16	Joint
A 0330	4	Shock damper
A 0204	4	Rollers for 1011
AMS 903	4	Cover for 1041
AMS07	2	Central filling plug
AMS13	4	Joint
AMS14	4	Joint
AMS 20	2	Rollers for 1031
TZ 5,5		Brushes
TZ 18		Brushes
U 0		EPDM gasket for glass fixing
U 00		EPDM gasket for glass fixing

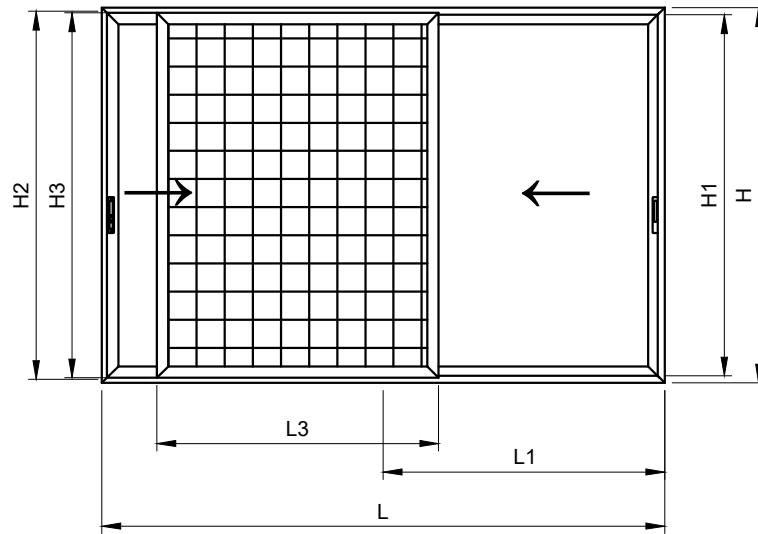

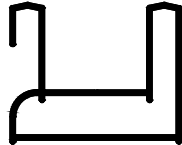
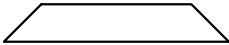
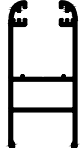
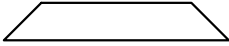
MINI SLIDING SYSTEM

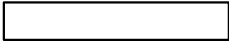
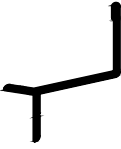
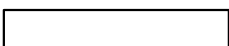

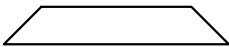
PROFILE CODE	DROWING	DESCRIPTION	CUTING SIZE	ANGLE OF CUTTING	NUMBER
1001		Frame profile	L		2
			H		2
1011		Sash profile	$L1 = L/2 + 5\text{mm}$		4
			$H1 = H - 54\text{mm}$		4
1041		Addition for double wing profile	$l = H1 - 35\text{mm}$		2
1051		Drop defender profile	$L2 = L - 1.8\text{mm}$		2
			$H2 = H - 1.8$		2
1031		Mosquito profile	$H3 = H - 66\text{mm}$		2
			$L3 = L1 - 5.5\text{mm}$		2

MINI SLIDING SYSTEM

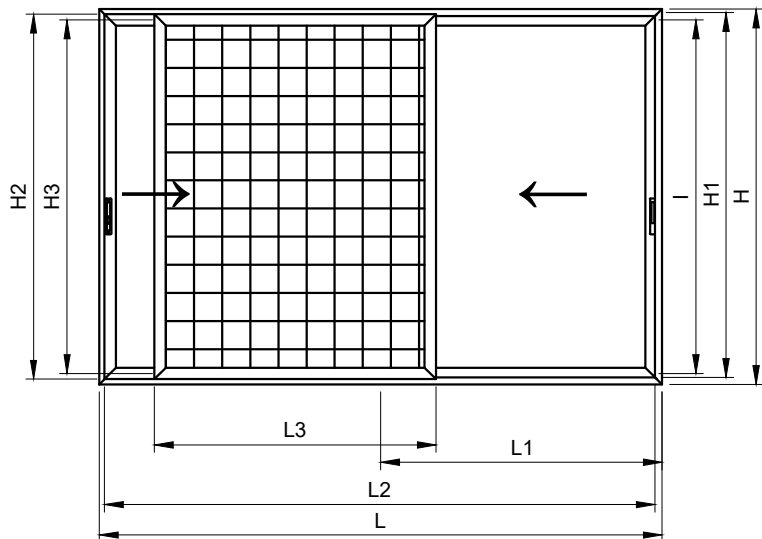



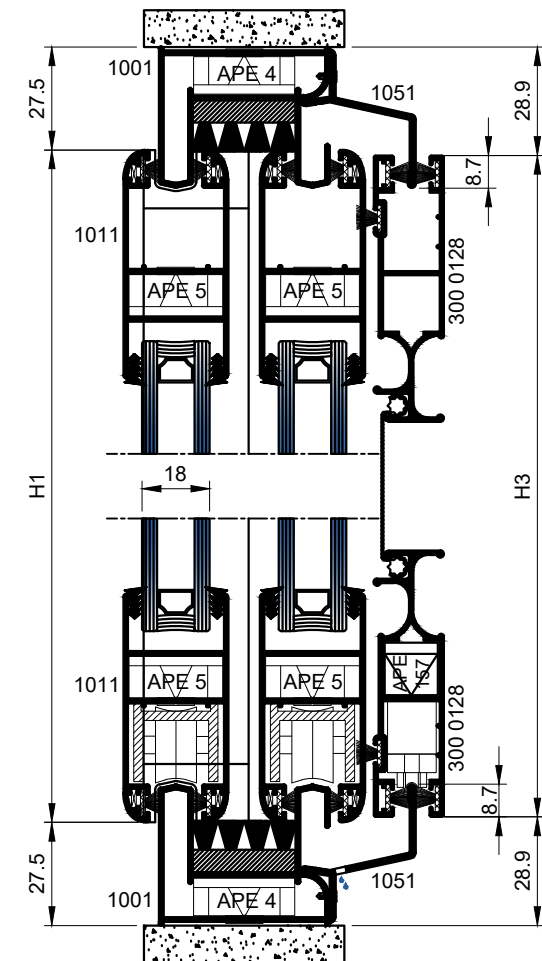
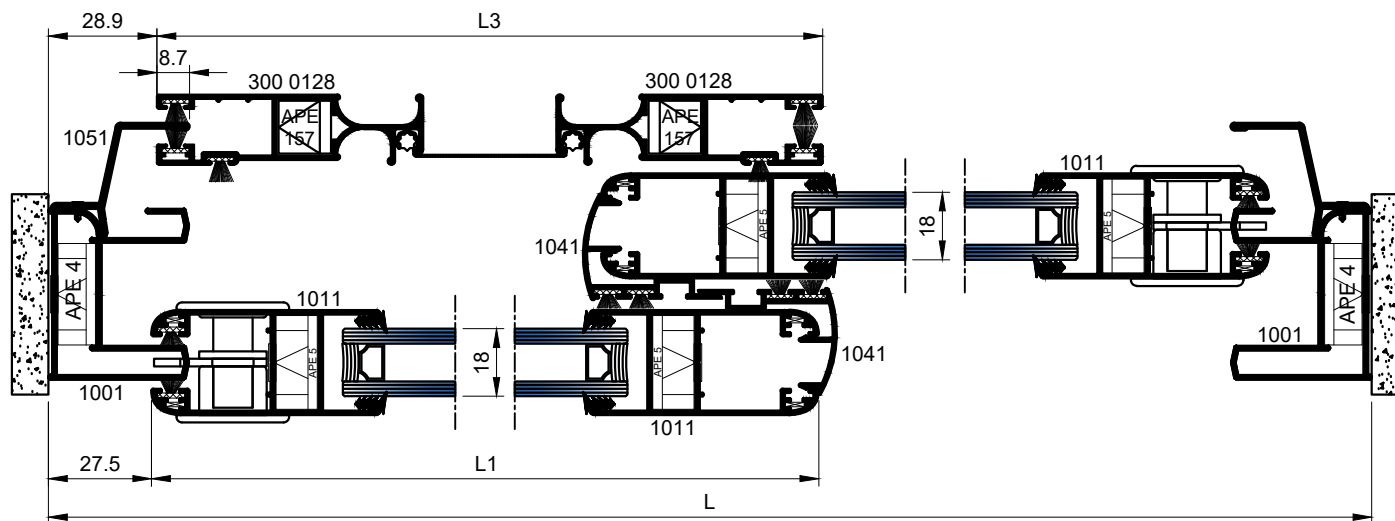

ACCESSOIRES		
CODE	PIECE	DESCRIPTION
APE 4	4	Joint
APE 5	8	Joint
APE 6	16	Joint
A 0330	4	Shock damper
A 0204	4	Rollers
AMS 903	4	Cover for 1041
AMS07	2	Central filling plug
APE 157	4	Joint
A0103	2	Rollers for 300 0128
TZ 18		Brushes
U 0		EPDM gasket for glass fixing
U 00		EPDM gasket for glass fixing

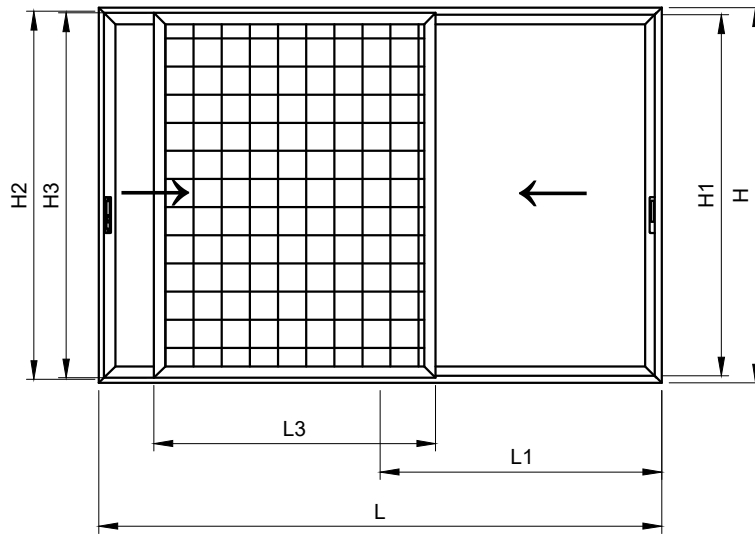

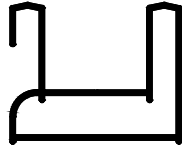
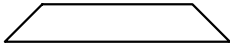
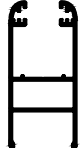
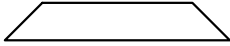
MINI SLIDING SYSTEM

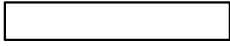
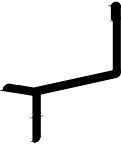
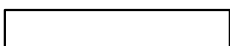

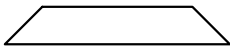
PROFILE CODE	DROWING	DESCRIPTION	CUTING SIZE	ANGLE OF CUTTING	NUMBER
1001		Frame profile	L		2
			H		2
1011		Sash profile	$L1 = L/2 + 5\text{mm}$		4
			$H1 = H - 54\text{mm}$		4
1041		Addition for double wing profile	$I = H1 - 35\text{mm}$		2
1051		Drop defender profile	$L1 = L - 1.8\text{mm}$		2
			$H2 = H - 1.8\text{mm}$		2
1031		Mosquito profile	$H3 = H - 58\text{mm}$		2
			$L3 = L1$		2